

Fiber Laser Beginner Class

100W MOPA Fiber Laser



LAST REVISED 06/20/26

Laser Training Outline

- Purcellville Facility Notes
- Introduction to Fiber Laser Equipment
- Guidelines and Policies
- Laser Safety Review
- Getting to Know the Machine
- Laser Engraving Process
- Introduction to Laser Software: LightBurn
- Tips, Hints, and having FUN
- Hands on Training and Use



Purcellville Location

- Bathrooms in both upper and lower classrooms.
- Padlock codes on the website behind Member login.
- Before locking the gate, check that no one is in the upper building.
- There are two locks on the front gate which should be locked together so either town workers or Makersmiths Members can open the gate. A sign on the gate has instructions
- When you leave the Frame Shop/Laser Room, make sure the mini-split is on and set to 70.



Laser Equipment: Purcellville

- We have a 100W MOPA Fiber Laser.
- This is a galvo laser, meaning that it moves the laser with mirrors rather than a gantry like our CO2 lasers.
- Fiber lasers fire in pulses whereas CO2 lasers are a continuous wave.
- Cutting area depends on the lens used
 - 2.7" X 2.7" (70x70) with the 100mm lens
 - 4.3" X 4.3" (110x110) with the 160mm lens
 - 8.2" X 8.2" (210x210) with the 290mm lens
 - Use of all three lenses is taught in the intro class and red tool trained people can use any lens.
- Passthrough is achieved by removing the front of the housing and is allowed after taking the fiber laser beginner class.
- Rotary and rotational attachments are available and will be taught at a later date.

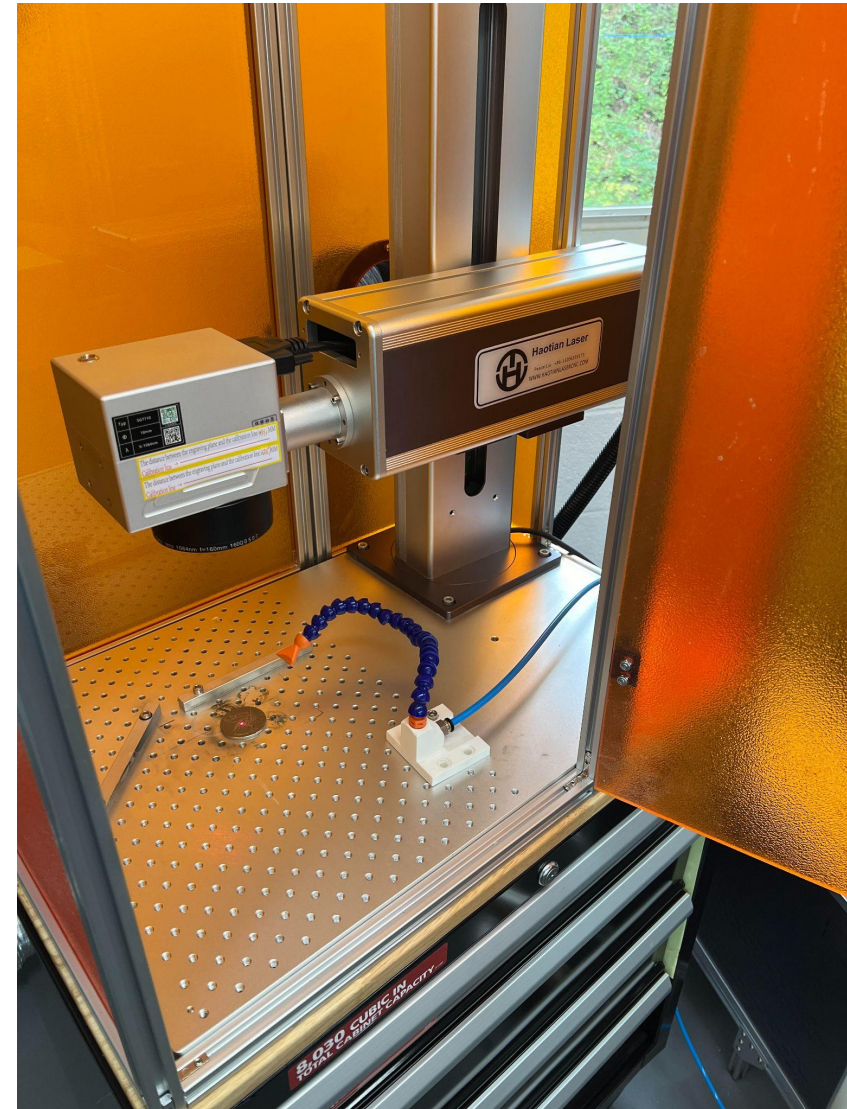

We Have 3 Lasers

- We have one 100W MOPA Fiber Laser in Purcellville
- Cutting area varies depending on the lens used
- Rotary and rotational attachments are available
- Best for engraving metals.
- **Certification on the fiber laser only applies to the fiber laser.**
- We have one 60 Watt CO2 laser in Purcellville and a 100 Watt CO2 laser in Leesburg.
- Cutting area is 23.6" x 15.7" with max thickness of 6.1" on the 60 watt
- Cutting area is 51.2" x 35.4" with max thickness of 9.1" on the 100 watt
- Both have passthrough, rotary attachments and multiple lenses.
- Best for engraving and cutting organic materials - wood, paper, cardboard, acrylic, leather, fabric, some foams, & some rubbers.
- **Certification on one of the two CO2 lasers certifies you for both CO2 lasers.**

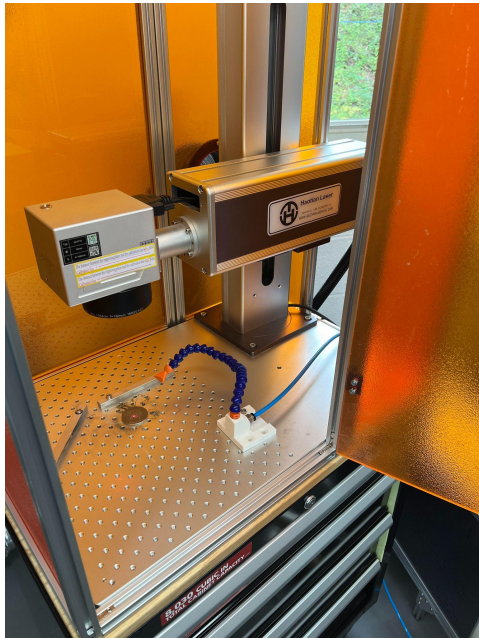



Policies, Safety & Materials

Guidelines and Policies

- **Sign the Makersmiths Waiver Form** - This can be done at the iPad in the Leesburg classroom or the Purcellville Green Room
- **The Laser is a Red Tool** – Red tools require safety training on a specific machine to operate unsupervised for safety and to prevent damage to the machine.
- **Schedule Your Time on the Laser** – Login to Makersmith.org. Go to [Reservations > Laser Reservations](#) and fill out the reservation form
 - Which laser, start and end times, your name
 - You will receive an email confirming your reservation. You can cancel your reservation from that email.
 - Limits:
 - 2 hours per day/10 hours per week
- **Record Time** - There is a poster on the wall with QR code, a label on the laser computer/desk, and a shortcut on the desktop that you can use to record your time on the laser. This is used to determine maintenance/cleaning routines. This does not require you to be logged into anything.



Laser Safety Review

- **DO NOT look at the laser while it is in operation.** This is even more important when using a fiber laser than a CO2 laser. It can blind you.
- **Wear 1064nm OD6+ safety glasses.** Even with them on, do not look at the laser as it is cutting.
- **Protect others.** Lock the door from the inside when the laser is in use, put the sign in the window, if you have half the case removed for passthrough, cover the windows through which people can see the machine.
- **The fiber laser DOES NOT shut off if the door is opened.** If you need to shut off the fiber laser in an emergency, press the Emergency Stop button. Do not open the door without turning off the laser.
- **Always be sure the external exhaust fan is in operation** before cutting/engraving.
- **Make sure you have focused the laser optics** to the top of your material with the right height for the lens you are using.
- **NEVER leave the laser running unattended!** Lightburn will let you pause mid project and start again right where it left off.
- **If material catches fire, DON'T PANIC.** Try blowing it out, remove it from the device, cover with a fire blanket, and as a last resort use the fire extinguisher.
- **Make sure that the material is supported outside the machine (front and back) if using the passthrough.** There are stand up rollers under/by the CO2 laser.
- **Don't cut or engrave materials that will create fires or produce toxic gases.** A list of these is in this presentation and at wiki.makersmiths.org.



Laser Eye Safety

- The fiber laser is more powerful than the CO2 Thunder Lasers we have at Makersmiths.
- As long as you leave the case on and the case door is closed, the chances of the laser bouncing off of your project material, going through the acrylic/aluminum case and hitting your eye is very low.
- However we recommend that you purchase a pair of safety glasses to wear when using the fiber laser.
- These glasses should block the 1064nm wavelength and be rated OD6+ or higher.
- You can find these glasses from many online suppliers.



Laser Safety Review: OK Materials

OK TO LASER List:

- **Metals:** Stainless steel, aluminum, brass, titanium, gold, silver, and tungsten. Care should be taken when engraving Manganese, Chromium, Nickel, Cobalt, Copper, Lead
- **Coated Metals** - powder coated, anodized, or painted metals like tumblers, business cards, dog tags etc.
- **Plastics:** acrylic, lucite, plexiglass (won't cut through clear)
- **Stone:** Brick, granite, and marble
- **Tile:** Can be engraved with a fiber laser

Other materials either should not be, or simply won't cut on a fiber laser. Use the CO2 laser for wood, leather, and other allowed materials.

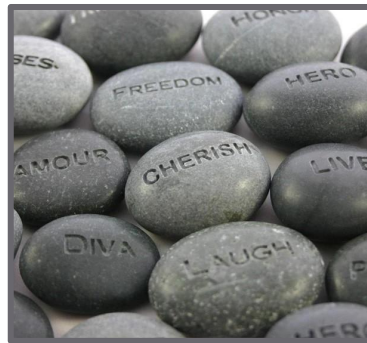

Laser Safety Review: DO NOT LASER

DO NOT LASER List

- Galvanized metals - releases harmful gases
- Carbon Fiber - the resin can melt and release harmful gases
- Any material that won't cut well or emits gasses
- PVC: produces hydrochloric acid and toxic fumes
- ABS: emits cyanide gas and tends to melt
- Polycarbonate/Lexan: cuts very poorly, discolors, catches fire, may contain chloride which is bad, might look like acrylic but is not the same thing
- Artificial leathers, Pleather: contains PVC and produces toxic gasses when lasercut
- High Density Polyethylene (HDPE): milk bottle plastic, melts and creates fires
- Foams like PolyStyrene or PolyPropylene: they catch fire
- Fiberglass: emits fumes
- Cellulose: combustible

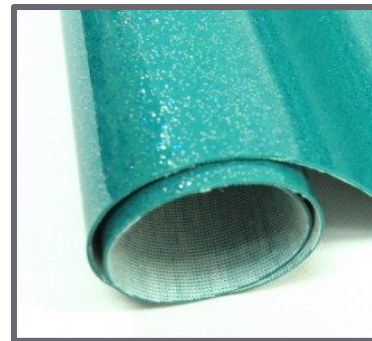



Getting to Know the Fiber Laser

Getting to Know the Machine: Switches & Air



- The main laser case looks like a desktop computer housing.
- The front has buttons that raise and lower the laser and an Emergency Stop button.
- There is a power switch on the back of the case, but turning it on and off should be done from the power strip.

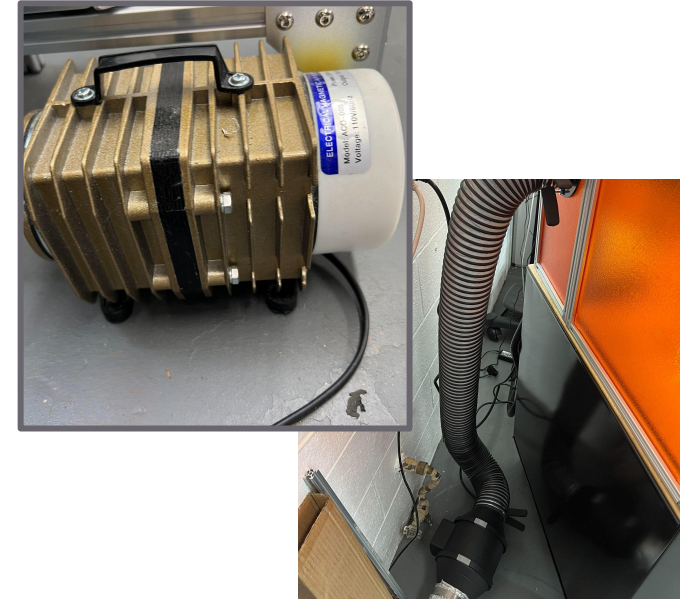

- All of the components of the laser have been plugged into the power strip attached to the side of the cart. Each switch is labeled.
- Turn on/off the laser, exhaust and air assist as needed.
- Leave the Computer and Monitor switches on at all times



- The air assist compressor does not have a tank and should just be turned on and off as you use the laser. There is no adjustment on the main compressor.
- The air extraction is turned on at the powerstrip on the side of the cabinet and can be adjusted by the dial that is inline on the cord.

Getting to Know the Machine: Case

The door on the front fits tightly into the frame of the enclosure so that it stays in place while projects are being engraved.

This machine **DOES NOT SHUT OFF** if the door is opened. **ALWAYS** make sure the laser is not firing before opening the door.

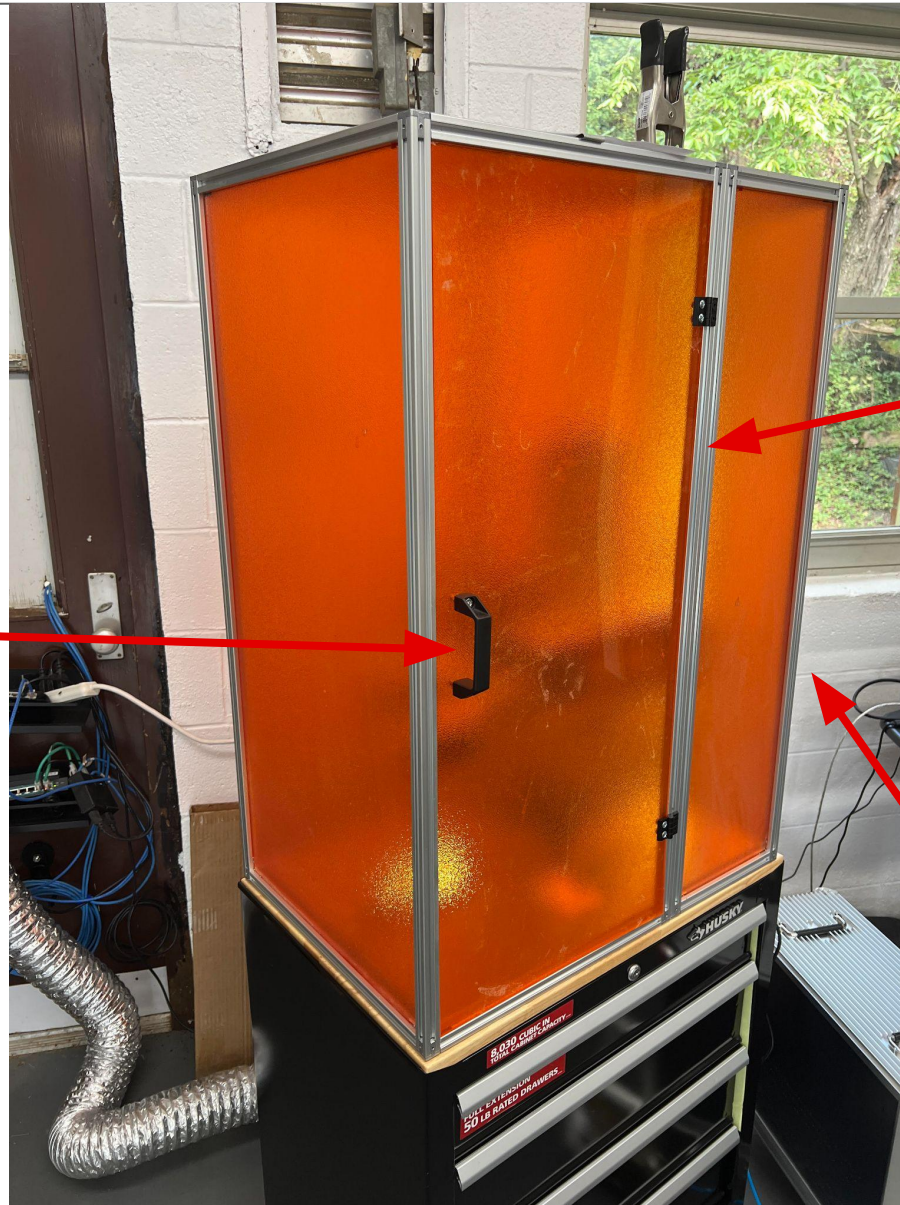

The case is in two parts so that the front half can be taken off to accommodate large parts. There are latches on the front and back to hold both parts of the enclosure tightly together.

The right side and back of the case have holes to accommodate air assist, power to raise and lower the gantry, and the air exhaust. The back section cannot be removed.

Getting to Know the Machine: Passthrough

If you remove the front half of the case to engrave something larger than the bed, it is even more important that you wear your laser glasses and put the sign on the door to the room to warn people that the laser is in use.

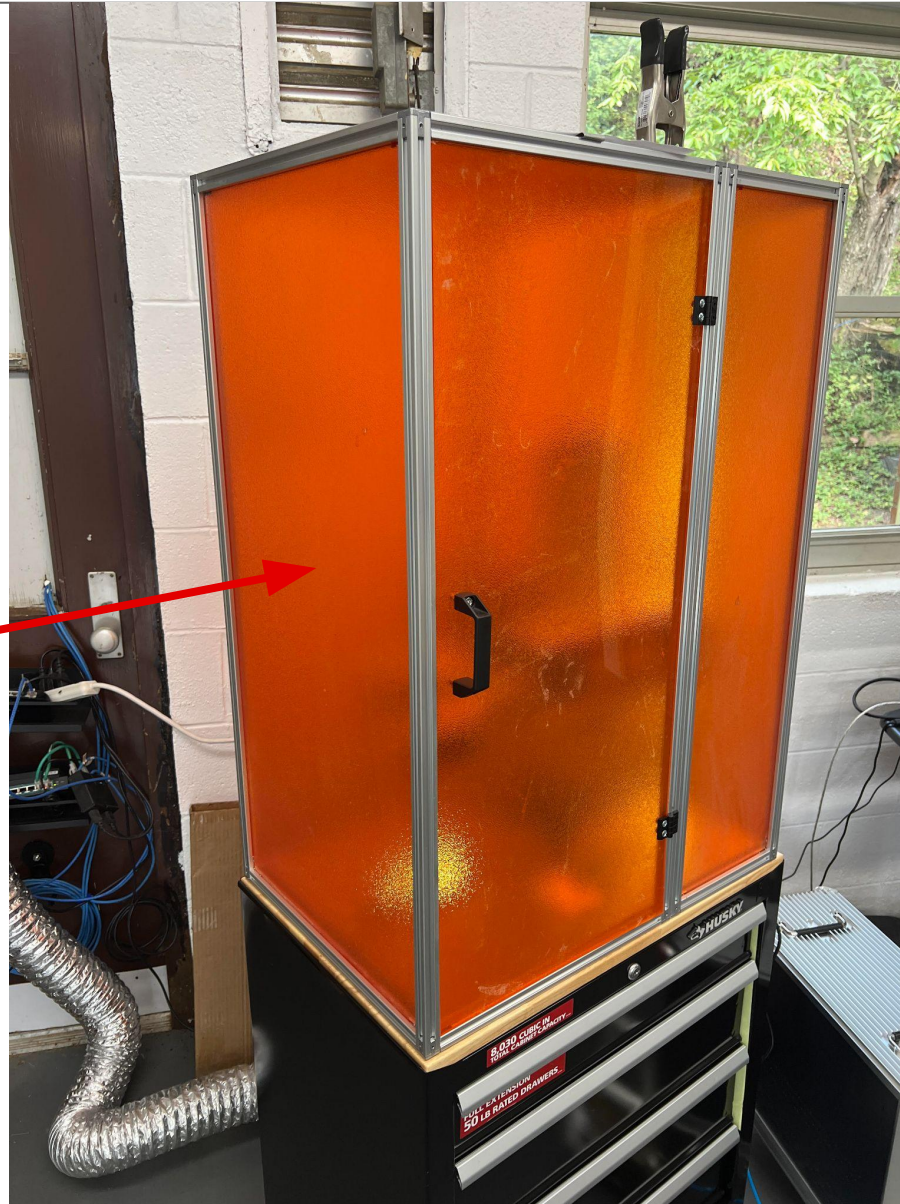

When you are done engraving with the front section removed, replace the front section afterwards.

If your project fits on the bed and you can align your workpiece/art, don't remove the cover unnecessarily.

Getting to Know the Machine: Bed

The bed has M6 holes for fixturing pieces to be screwed to the bed as needed.

The bed is larger than the area it is possible to engrave on.

100mm = 2.7" x 2.7"

160mm = 4.3" x 4.3"

290mm = 8.2" x 8.2"

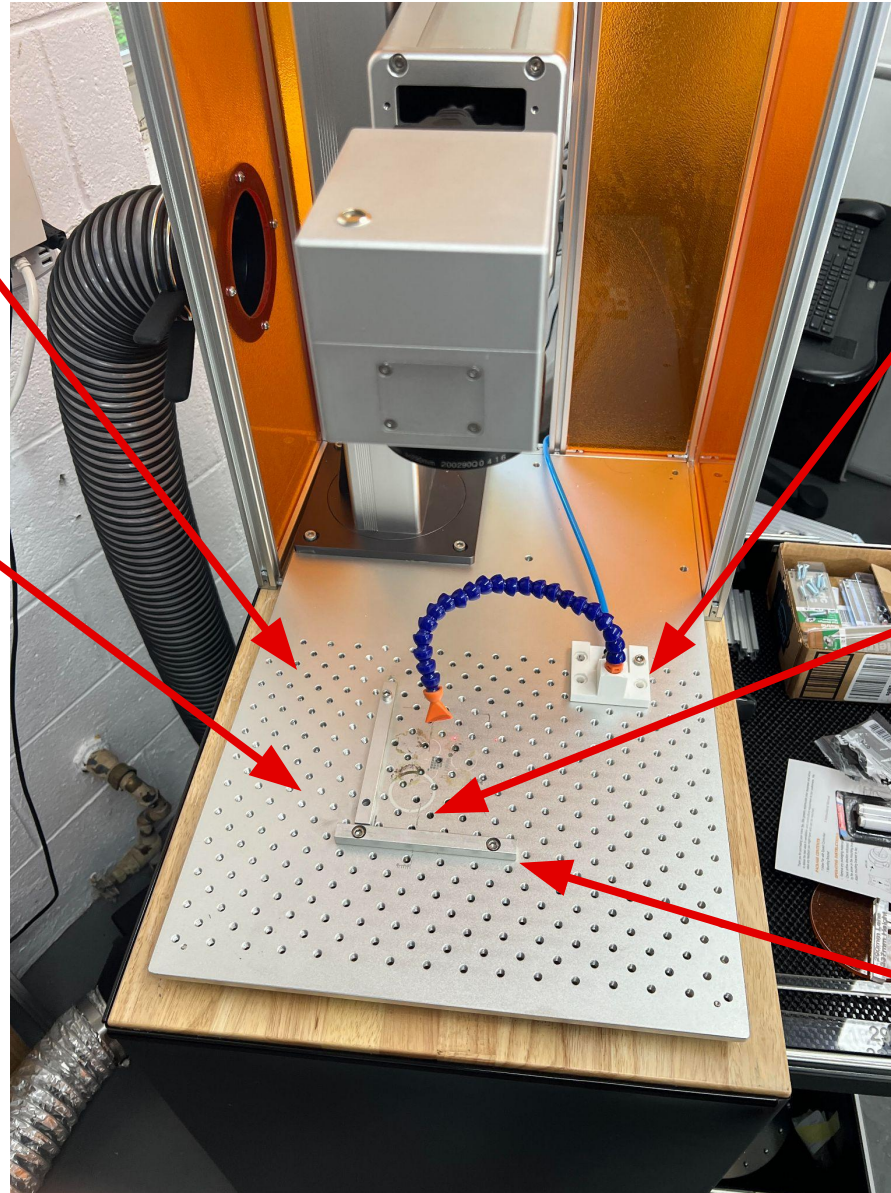

The air assist base can be moved around the bed and kept in place with one or more M6 screws.

If you want to engrave at or over the edges of your project material, place a piece of metal between your project piece and the base as a spoil board. Otherwise you could engrave into the bed.

There are a few fixturing pieces available for use. You can make, buy, laser cut or 3D print your own fixturing pieces. If you 3D print, use PLA, not ABS.



Getting to Know the Machine: Bed

Holes for M6 cut on the laser at 6.5mm gives a slightly loose fit.

All other measurements below in mm and the pattern can be repeated wherever on the jig you want to put them.

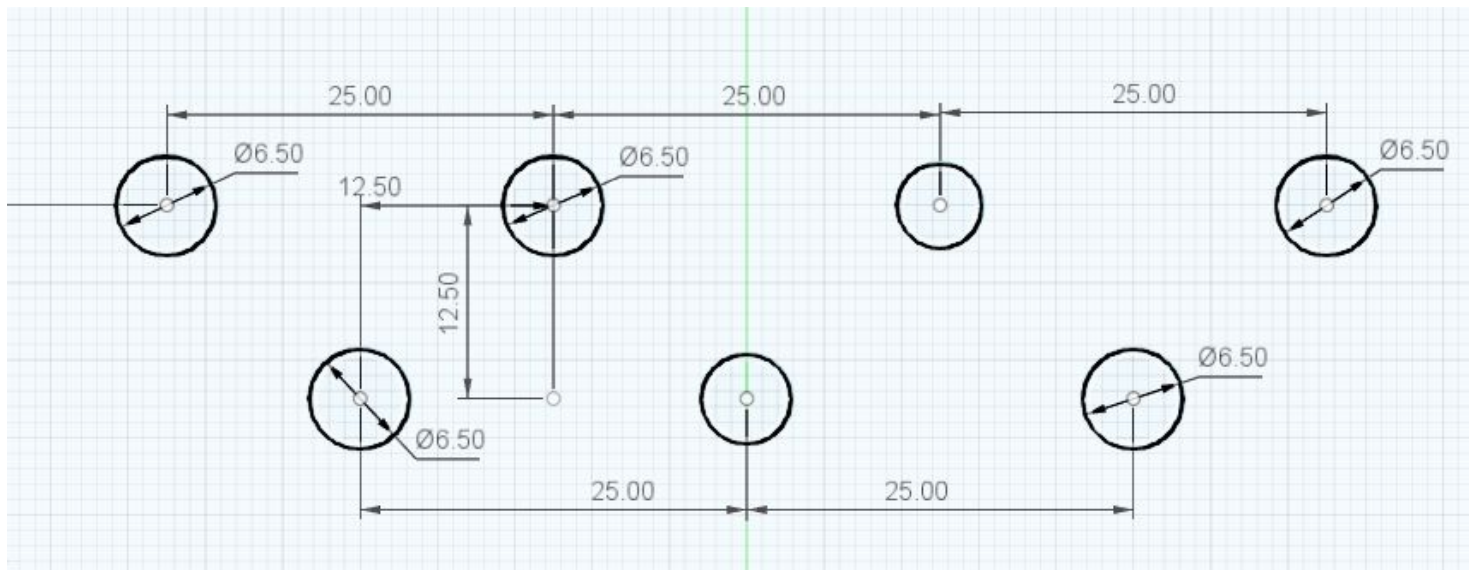

Riser for 100mm Lens

When using the 100mm lens, you will have to raise your workpiece up off the bed in order to focus laser to your material.

Use risers and/or M6 screws depending on your application to raise the bed height up to accommodate the 100mm lens.

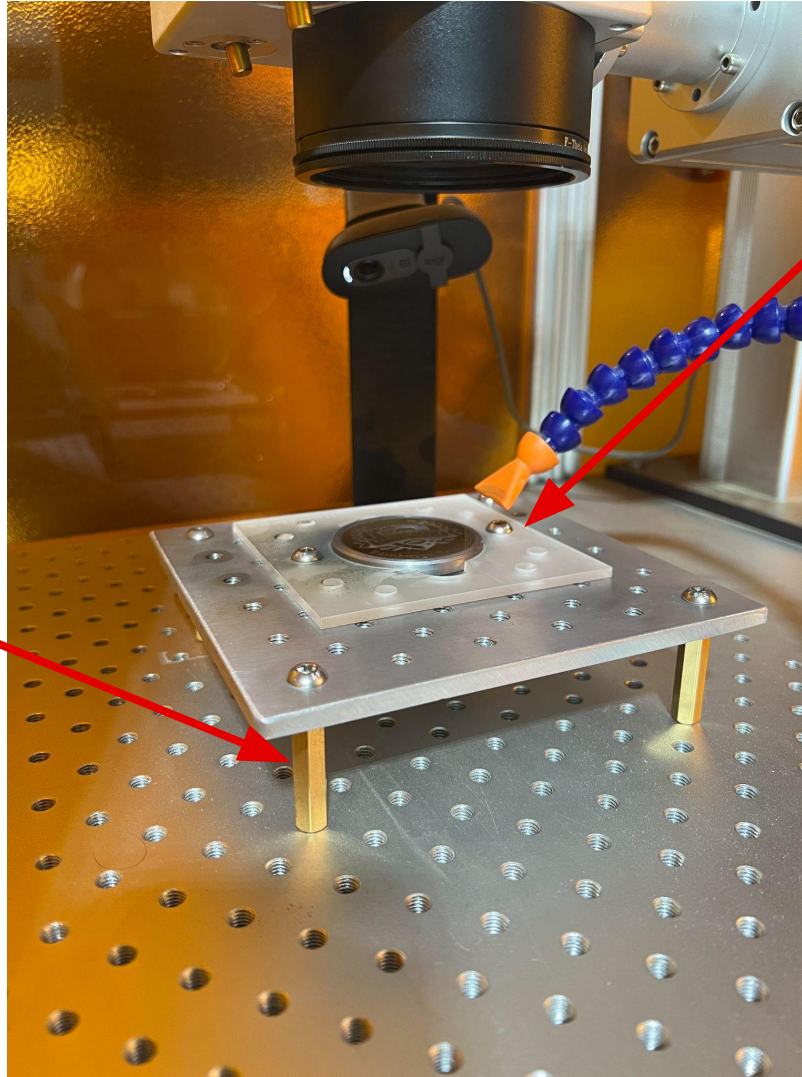

All holes except the corner holes are M6 threaded so you can secure jigs to it.

Getting to Know the Machine: Important Buttons



- The fiber laser has no air or machine control panel. The only hardware buttons are outlined below. All other machine control is done through LightBurn.

- There is an emergency stop button on the front of the case and this is the quickest way to stop the machine in case of a fire, emergency etc.
- You can also stop the machine by pressing “Pause” or “Stop” in LightBurn.
- The up and down arrow buttons raise and lower the laser height more quickly than turning the handle by hand.



Getting to Know the Machine: Lenses

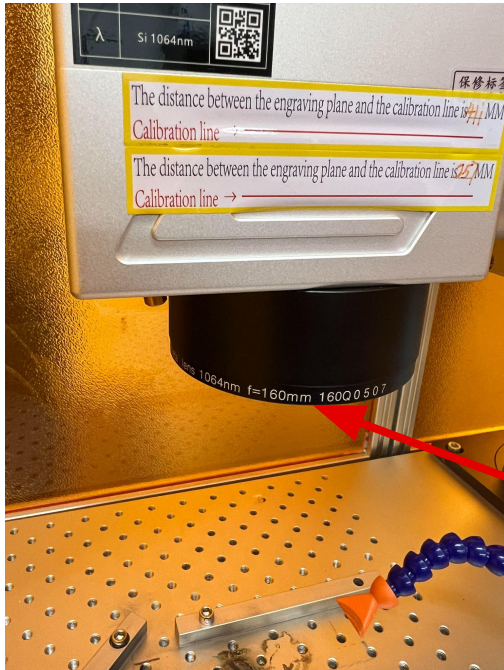

- There are three lenses that you can use on the fiber laser - 100mm, 160mm, and 290mm.
- Smaller lenses will deliver more power at the same power/speed settings but sacrifice engraving area size.
- Example - the 290mm lens will let you engrave in an area approximately 8.2" x 8.2", but the power actually applied across the area will be lower at the same power/speed settings compared to where a 160mm lens is used. If you value efficiency, use the smallest lens you can.
- The lens focal length is written on the side of the lens.
- To remove a lens, grip the bottom of the lens and turn clockwise (as you look at the lens from above) to loosen the lens. Turn and be careful not to drop the lens. Put the plastic covers on both the top and bottom of the lens, and put it away in the lens box.
- To install the other lens, remove both plastic covers, gently put the small end of the lens into the housing and turn slowly counterclockwise until the threads catch. Do not force the lens into the housing. Hand tighten only. There are no exterior moving parts on the lens that would cause it to loosen over time.
- Each lens is setup as a different Device in LightBurn. I.e. each lens is treated as a separate machine and you need to select the correct one.

Getting to Know the Machine: Air Assist

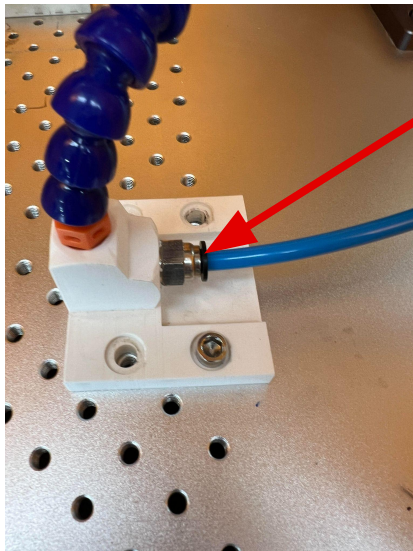
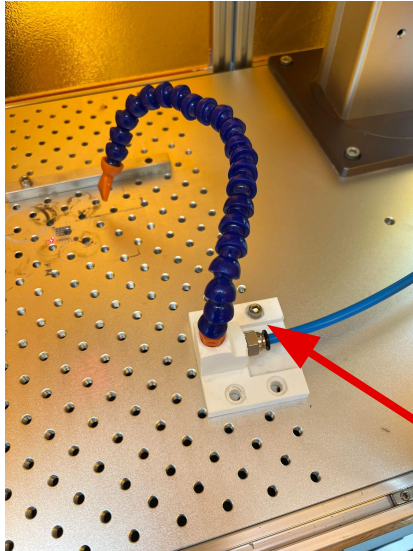

- The air assist helps to keep engraving dust clear of the laser when you are running more than one pass.
- You can move the air assist around on the table by moving the base and adjusting the end to where it needs to be used.
- The air assist hose can be removed from the base by pressing in on the black ring on the air hose and gently pulling out the air hose.
- The air hose can be replaced by pushing the air hose back into the housing until you hear a “click” noise.
- Air assist is turned on by turning on the switch on the powerstrip attached to the side of the cart.
- Unless you have some extremely thin material, the air assist is not powerful enough to move your workpiece.



Setting Up to Laser Cut/Engrave

Laser Setup: Focusing the Laser

There are three heights of laser focusing tools, and multiple different sizes of each.

- If using the 100mm lens, use a height gauge labelled “100mm Lens. 115mm height”
- If using the 160mm lens, use a height gauge labelled “160mm Lens. 198mm height”
- If using the 290mm lens, use a height gauge labelled “290mm Lens. 337mm height”

Put the bottom of the gauge on top of your workpiece, and adjust the height so that the bottom of the lens housing touches the top of the gauge. Do not touch the glass of the lens.

You can move your workpiece to make it easier to adjust the height of the lens, then move your workpiece into the right position for engraving later.

You raise and lower the height with the buttons on the front of the case, or by turning the handle on top of the gantry. The buttons should be used for fast moves and turning the handle should be used for fine adjustment.

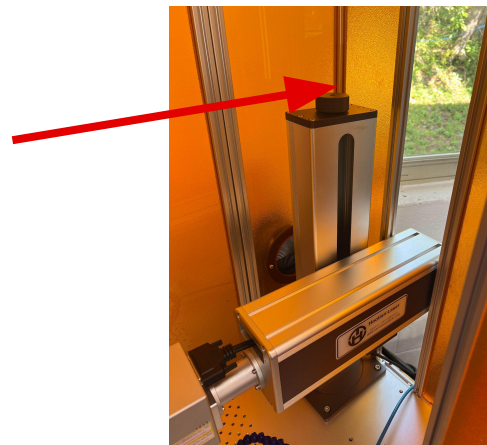
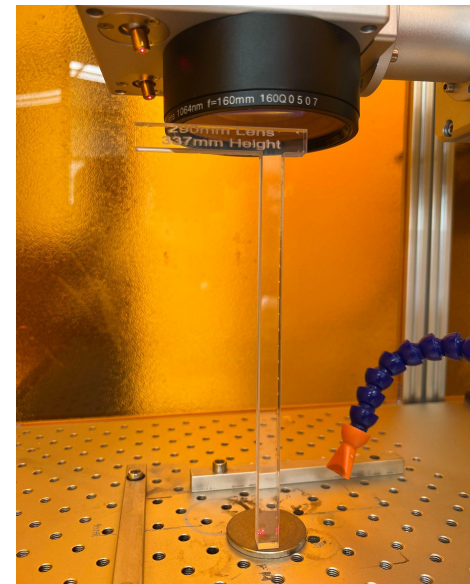

Laser Setup: Alignment

If you will be engraving over the edges of your project piece, put a piece of metal underneath to avoid marking the bed.

Unlike our CO2 lasers, you cannot change the start origin point on a galvo laser. The origin is always the center of the work area.

To align your workpiece to the engraving/cutting area, you will use the “Frame” function in LightBurn to line your workpiece up to the frame and/or adjust your artwork to align with your workpiece.

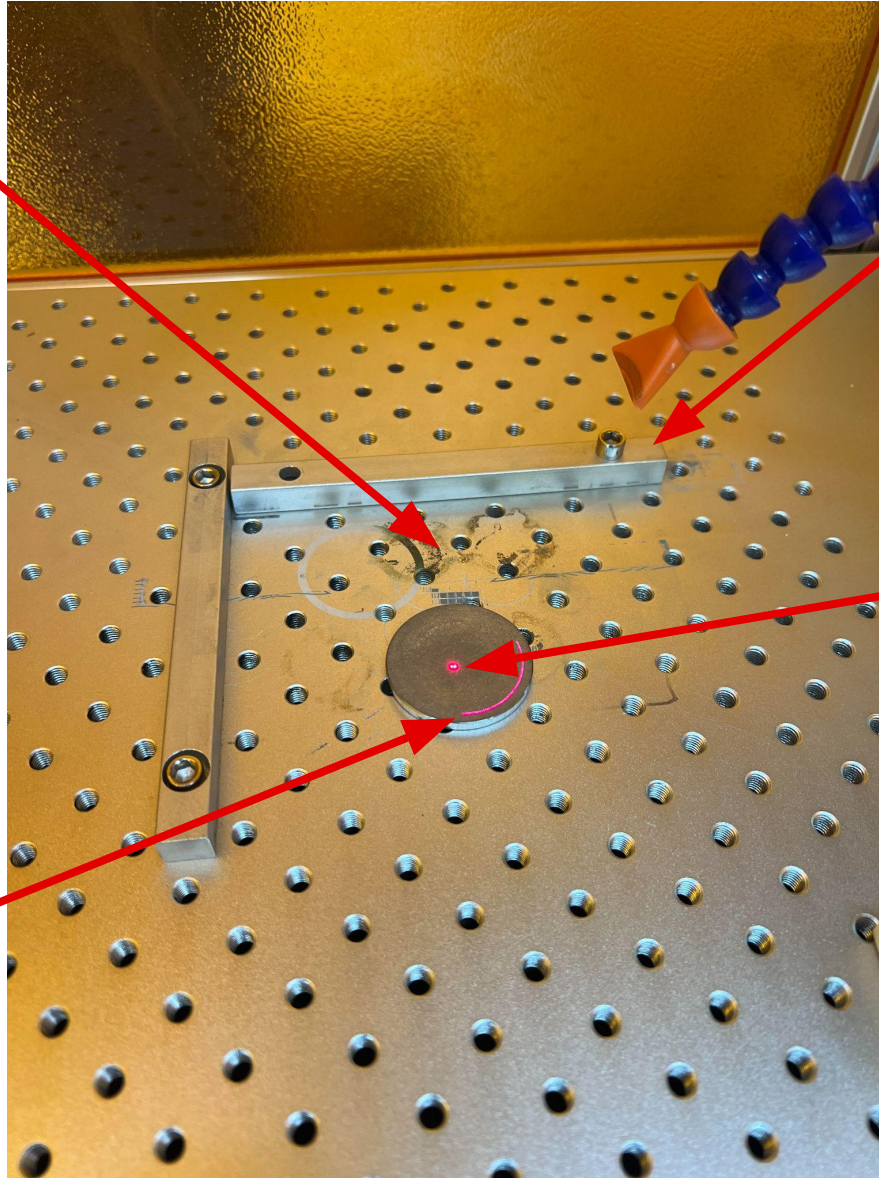

You can use the the fixture pieces (existing with the machine or your own) for a repeatable method to engrave in the same place on each workpiece.

As of the date of these slides, the center point marker IS NOT aligned correctly. Use the “Frame” function to align your workpiece.



Getting to Know LightBurn

Laser Software - LightBurn

LightBurn Software

- In Lightburn you can preview, edit or create artwork. It also controls the laser cutters.
- We have a limited number of Makersmiths licenses available. There is one for each computer attached to a laser, and one for the Leesburg Classroom.
- You can download a 30 day trial and/or purchase your own copy. If purchasing you will need to buy the Lightburn [Pro License Key](#).
- Lightburn has a program for members of makerspaces to get a 75% discount on a single seat license of the software. This is so members can work on their own computers to design their projects and then just jump straight into cutting when they come in to use the cutter. NOTE: this is only for use with the lasers in the space. If you own your own laser, you need to buy a full priced license. The code is a pinned message in the #lasercutter Slack channel but not in this slide deck because these slides are posted publicly.
- This is good for the DSP (thunder lasers) and Galvo (fiber laser) licenses.
- The device/machine and preferences files for LightBurn are on the wiki so you can setup your own copy exactly as it works on the computers attached to the lasers.



LightBurn: Opening/Importing Your File

To get the most out of a laser cutter, your files will primarily be vector files. The laser uses the vector pathways as a guide when cutting. Raster files can also be used, but are not as vector files. You can find more info here: [Raster vs Vector Files](#)

Most Commonly Used Vector Drawing Programs:

- Adobe Illustrator: Subscription based, around \$50 a month, with discounts for students. We have a license available at each location.
- CorelDraw: One time cost. We have a license available at each location.
- Inkscape: Free, with some small limitations relative to the paid options. A copy can be found on most of our computers.
- Fusion360: Free “Hobbyist” version, sketches can be exported as .DXF files for import to Lightburn. Useful for very precise drawing.
- Others: Other vector/CAD drawing programs are available, but may take some more work to get the file ready.

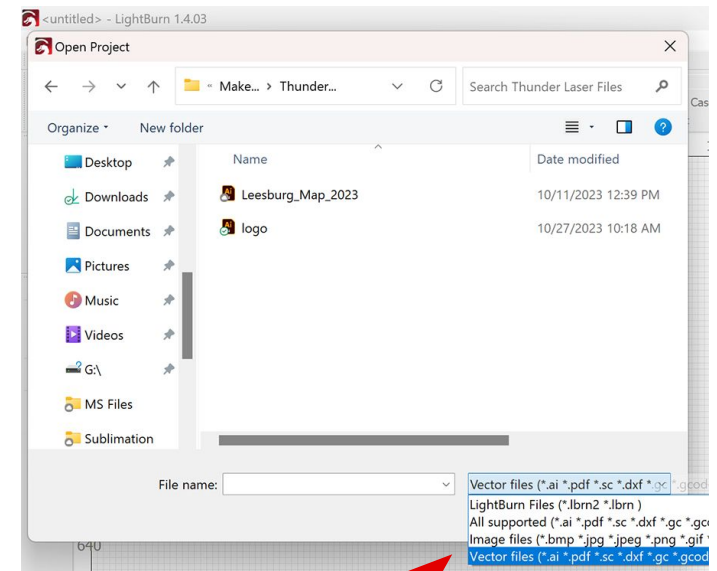

Open LightBurn and go to File > Open and choose your file. You may not see it right away, since LightBurn defaults to its own file format. To get to your file go down to the bottom right corner, next to the “File name” bar and click the extension box to see other file options.



LightBurn: File Types

- LightBurn can accept many file types!
- LightBurn requires the SVG import source to be set in the LightBurn software, else your design may import and be the wrong size, particularly if you use Illustrator. When you start your project, you should go to File - Preferences- Import Prefs. Load the Default Preferences file from the Desktop folder based on whether you will be importing SVGs from Inkscape or Illustrator. If you don't want to use or can't find the Default Preferences file, you can go to Edit - Settings - Import/Export tab at the top, and on the right side choose the SVG Import Settings that match the SVG source. If using Corel Draw, either setting will work.

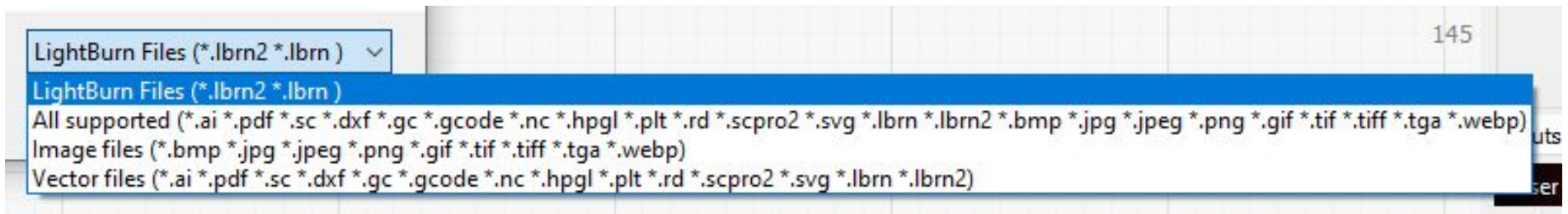

- LightBurn does not require specific line weights and colors. It just needs vector lines or shapes and you specify what is done with each object.
- You can also import raster files for photo engraving.
- If you want specific shapes to be engraved with the same power/speed etc. settings, make them the same color in your original art. This will save you time later on.

LightBurn: File Setup

Let's get to know this screen...

The screenshot shows the LightBurn software interface with several key areas annotated:

- Preview Button:** A red circle highlights the preview button in the top toolbar, with an arrow pointing to the text "Preview Button: see the lasers path and time".
- Layer Power, Speed, Pass Count, Interval, Q-Pulse and Frequency Settings:** A red arrow points from the "Cuts / Layers" panel to the settings for layer C01, including Speed (2000.0 mm/s), Power Max (35.00%), Pass Count (2), Interval (0.0100 mm), Q-Pulse (200 ns), and Frequency (144.0 kHz).
- Order of Operations:** A red arrow points to the "Order of Operations" panel on the right side of the interface.
- Layer Color Options (you get to choose!):** A red arrow points to the color selection options for the layer in the "Cuts / Layers" panel.
- Boundaries Check:** A red arrow points to the "Frame" button in the "Laser" control panel.
- Laser Controls Tab:** A red arrow points to the "Laser" control panel, which includes "Start Job", "Pause", "Stop", and "Start" buttons.
- Materials Library Tab:** A red arrow points to the "Materials Library" tab at the bottom of the interface, which shows a grid of material options numbered 00 to 29.

No origin selection when using galvo



LightBurn: CO2 vs Fiber Laser Differences

Let's get to know this screen...

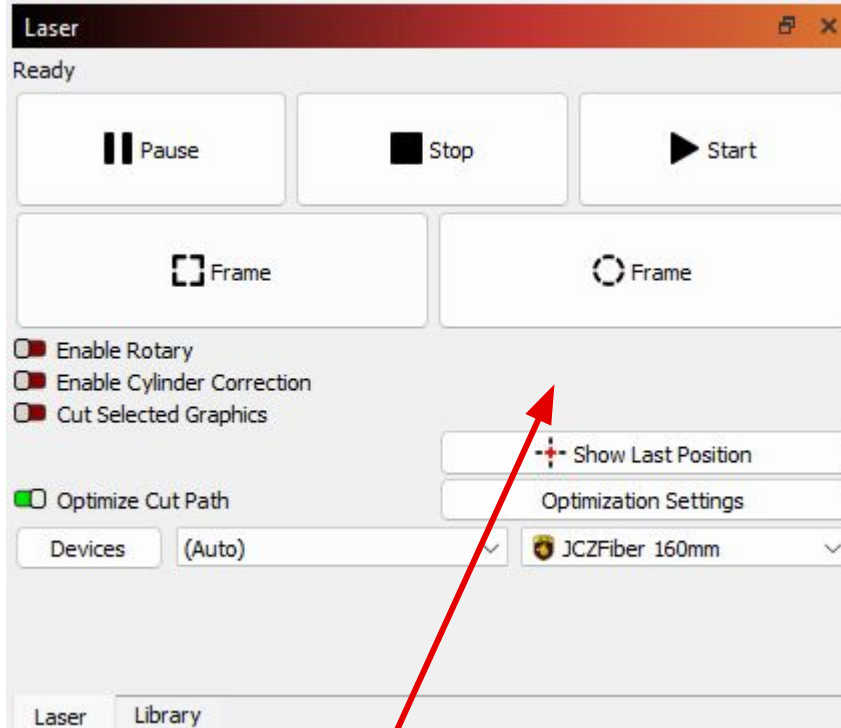

There is no option to change the origin point. The origin point is always the middle focus point of the laser.

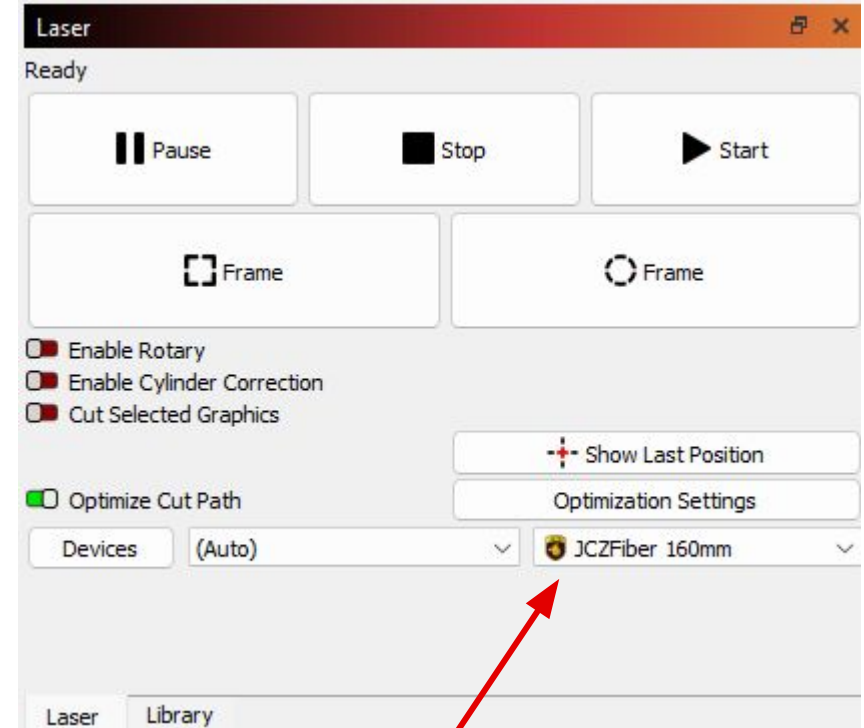

Each lens is set up as a different device. You must change the Device to match the lens focal length you are using. There are only two choices and they are labeled with the focal length.

LightBurn: CO2 vs Fiber Laser Differences

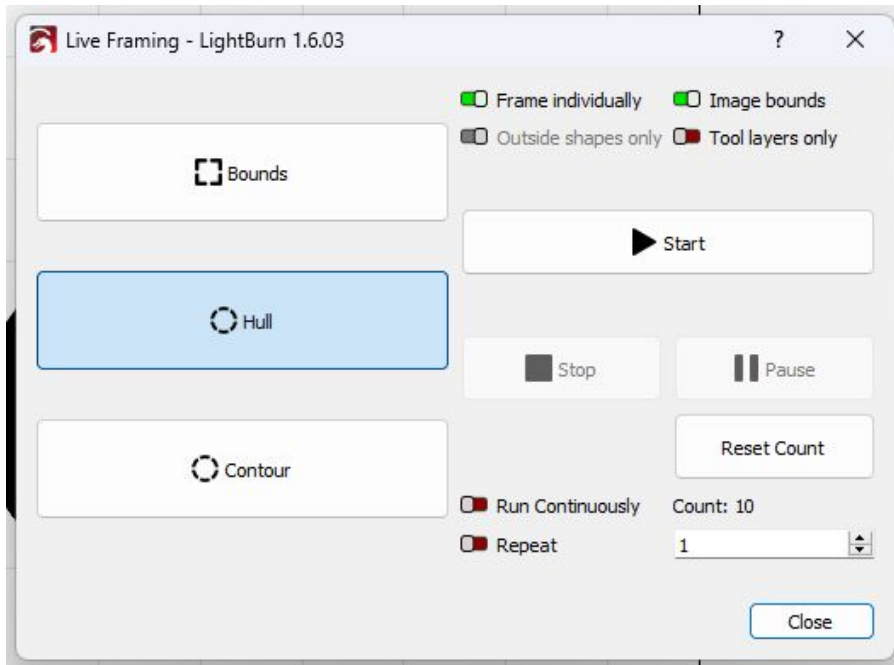

The Live Framing screen will always come up after you press start. There are three framing options. You will hit Start again on this screen when you are ready to start. You can make your engravings Run Continuously, or Repeat X number of times.

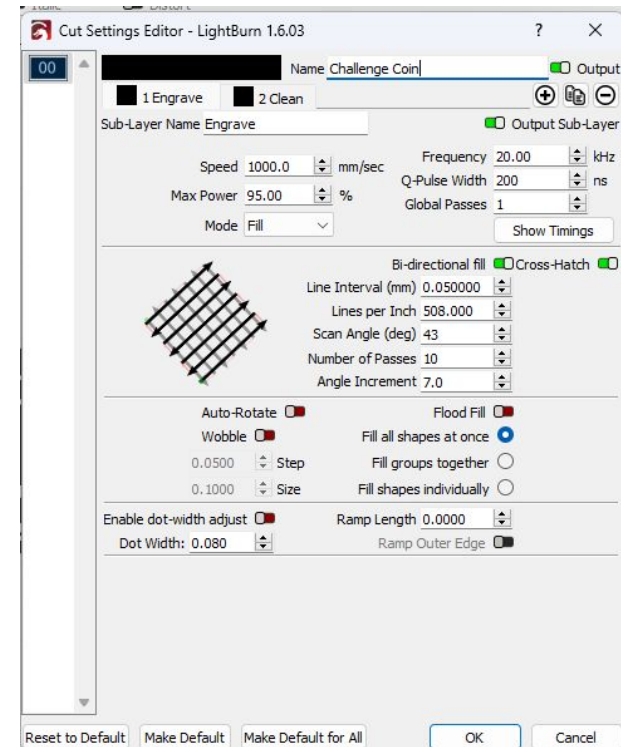

For anything more than removing a coating on metal, you will most likely run more than one type of engraving pass. You can do this with multiple layers, or you can set up sub-layers within a single main layer and run each at different settings and number of passes. Example: run 10 deep engrave passes followed by one cleanup pass, and repeat that over and over.

LightBurn: Origin



- When using a galvo laser, there is only one origin point - that is the center of the lens's cutting area.
- The origin section of LightBurn is hidden when using a galvo laser.
- To align your workpiece, press "Frame" to see where your workpiece will be engraved.
- From here, you can move your workpiece so that it is in the correct position, or you can move your art around on the canvas in LightBurn until it lines up with your workpiece. It is often a combination of these two that will be quickest to align your workpiece.
- If you plan to make multiples of one project, it would be helpful to create a jig, then align your artwork to match it.
- Unfortunately "Print and Cut" doesn't work on the galvo laser.
- [LightBurn Information on Framing with a Galvo Laser](#)



LightBurn: Layer Settings

- The ratios of Speed, Power, Frequency, Interval, Passes and Q-Pulse can make a substantial difference in the quality your engraving as well as how long it takes you to complete.
- **Power** is the intensity/power of each laser pulse/fire.
- **Speed** is how fast the mirrors/laser moves
- **Frequency** is how many pulses the laser fires per second. The more pulses, the smoother the image, but the lower the power per pulse.
- **Interval** is how many lines per inch/mm are engraved when using Fill mode.
- **Q-Pulse** - is the time between the start and end of each pulse of the laser, and it interacts with frequency to create color engraving on stainless steel and titanium.
- There are no simple recommended base settings with the fiber laser, but there are test pieces available in the drawers underneath the fiber laser.
- TEST TEST TEST. Always test your material with different fill and line settings before doing your final project.
- Once you find the settings that work for your material, save that information (Google sheet, notebook, OneNote etc.) so you can use those settings again in the future.
- Remember that the different lenses will require different settings. More power at the same power/speed settings will be delivered with the 100mm lens than the 160mm than the 290mm lens. Settings that worked on one will not necessarily give the same result on the other.
- You can choose the order in which the laser cuts and engraves by pressing the arrows on the far right of the “Cuts / Layers” window.
- You can also use sub-layers to do different types of engraving passes.

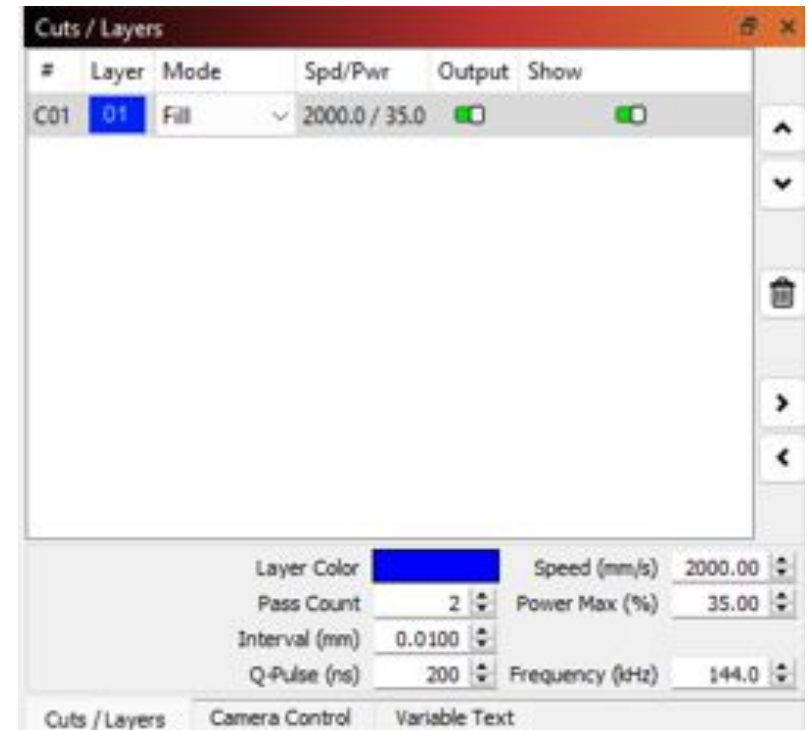

LightBurn: Layer Settings

- Most YouTube videos showing deep metal engraving suggest doing a number of engraving passes followed by a cleanup pass.
- Most recommend “Bi-directional fill” and “Cross-Hatch” with a Scan angle that is greater than 0.
- The “Angle Increment” will adjust the angle of the engraving between passes.
- There are many other settings worth researching if you want to optimize for quality and/or efficiency.
- Make sure to click the “Show Timings” button to make sure that the global timing settings have not been overridden by the specific layer settings that someone before you changed.

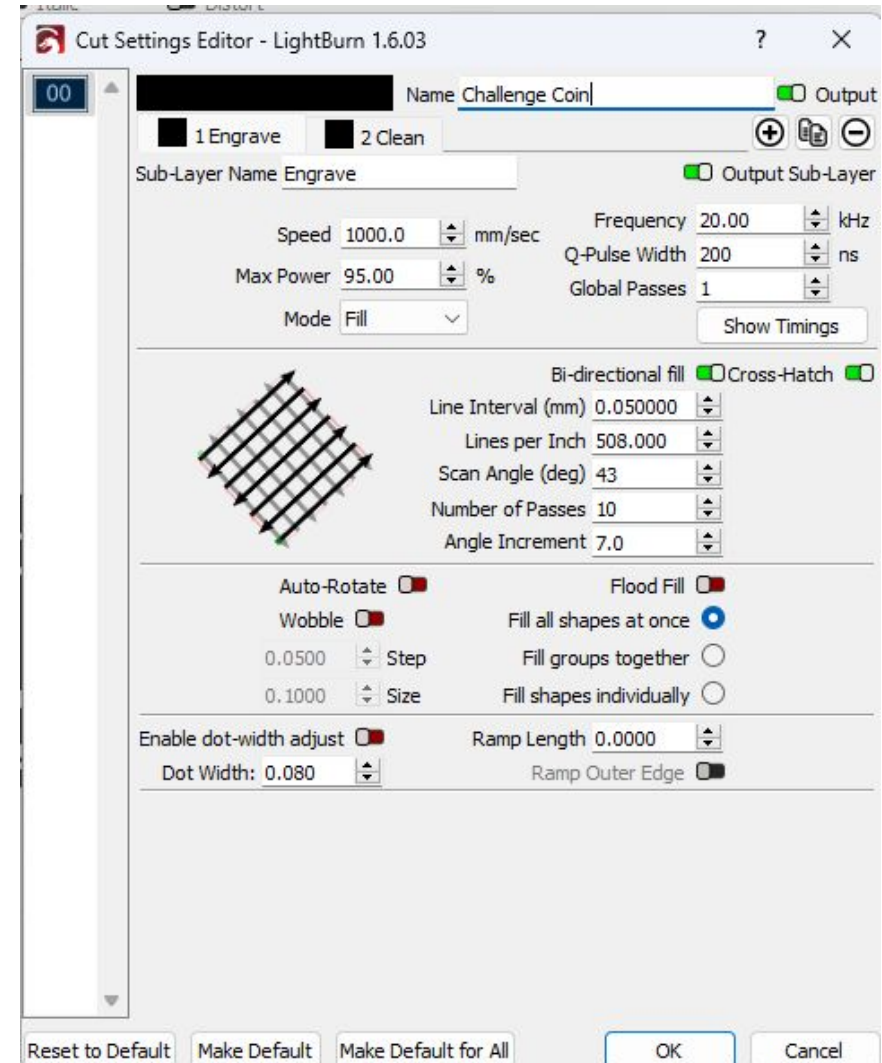

LightBurn: Other Tips & Tricks

- There is no “Air Assist” option because the fiber laser does not have automatic air assist. You can turn on air assist manually at the switch attached to the cabinet.
- The fiber laser top engraving speed is 4000mm/s. With no large moving parts, you can engrave at high speeds.
- The “Preview” button at the top of the screen is useful to find out how long your project will take as well as make sure your cut/fill/layer settings are correct before you get started.
- If you want to change between metric and imperial, you can do so by clicking on the button here.

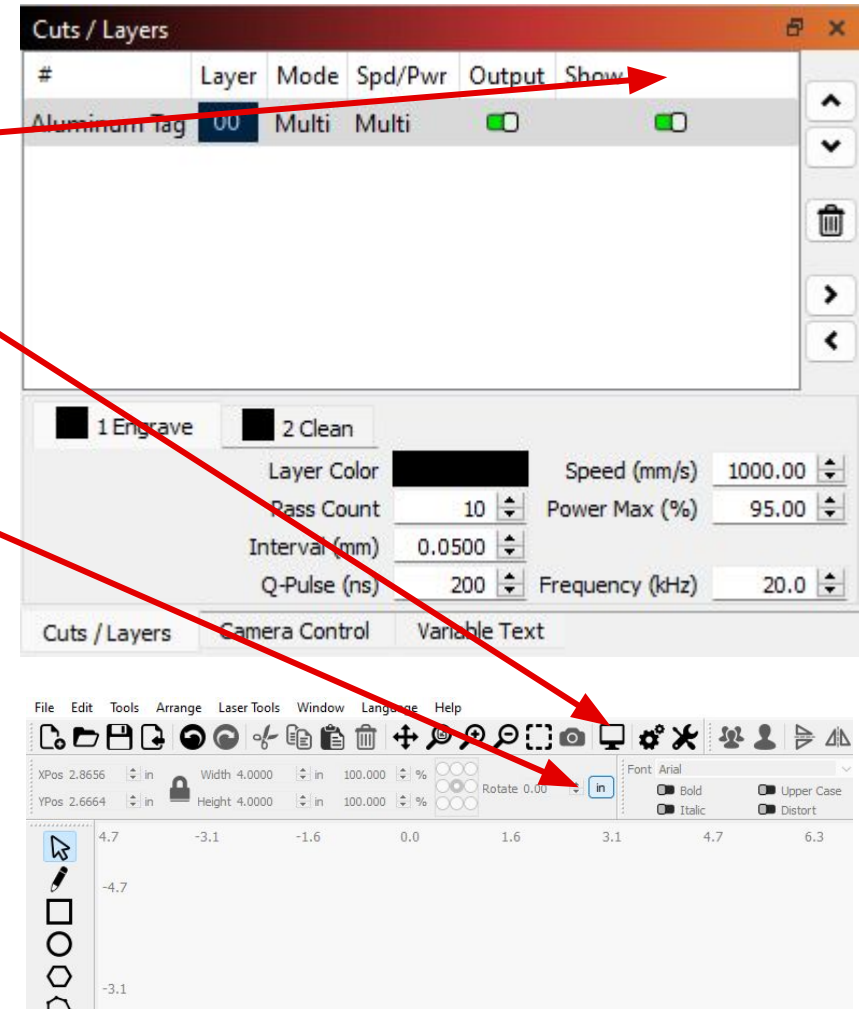

LightBurn: Material Test Cards

Any recommended settings you find online or are developed at Makersmiths are only starting points and not necessarily the best settings. You should do a test on your material before starting your full project. This will allow you to see what the engraving will look like with different setting combinations.

LightBurn has made it super simple to make one with different settings for your material. The widget can be found in the top left menu > Laser Tools > Material Test.

T

On the fiber laser, this is particularly helpful if you are trying to get color engravings.

LightBurn tutorial: <https://docs.lightburnsoftware.com/Tools/MaterialTest.html> or other YouTube videos.

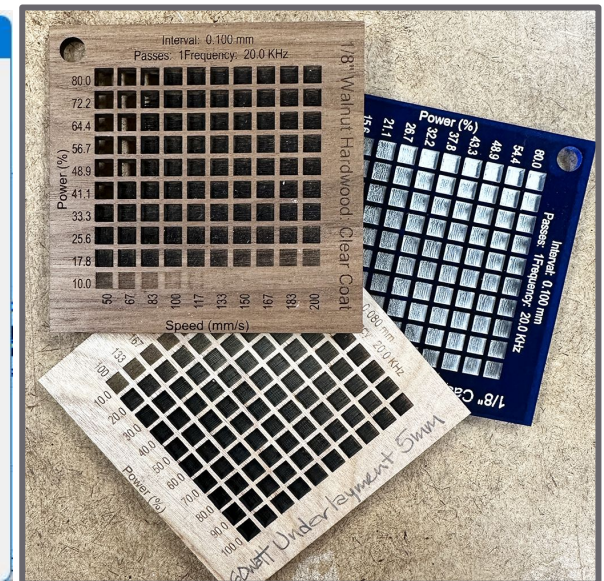
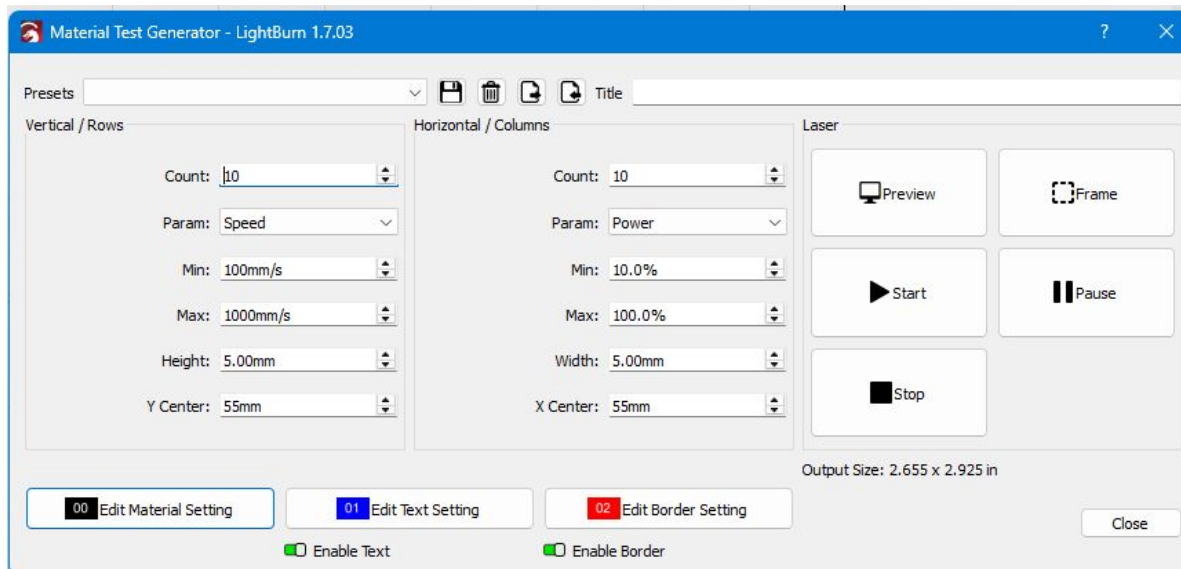

Fiber Standard Pre-Start Checklist

- Turn on the computer and monitor if they are not already on.
- Turn on the “Laser” switch on the power strip
- Check that the correct lens you want to use is installed. Swap if necessary.
- Open LightBurn.
- Go to File - Preferences- Import Prefs. Load the Default Preferences file from the Desktop folder. Use the file labelled with “Adobe” for Adobe Illustrator SVGs. Use the “Inkscape” file for SVGs or files from any other software.
- Select the Device (bottom right in LightBurn) relative to the lens you have installed-100mm,160mm or 290mm.
- Import/open/create your art as appropriate. Use “Open” for Lightburn files, “Import” for all other file types.
- Check or set all speed/power/passes/interval/frequency and Q-Pulse layer settings for each layer.
- Place your workpiece on the bed. Place the correct acrylic focus tool on top of your material. Using the buttons on the front of the laser and/or the dial, adjust the height of the laser for the lens you are using.
- Place the air assist on the bed and secure it to the bed with at least one screw. Adjust the nozzle as needed.
- Open the “Camera” application on the computer. Place the webcam on the bed and align so that you can see your workpiece on the monitor.
- In LightBurn, press the “Frame” button which will show a red outline of the area to be engraved. Move your workpiece, or move your artwork until correctly aligned. If you move your artwork, you will have to go in and out of the “Frame” menu until everything is aligned. Make sure that no wires and the air assist won't be hit by the laser when engraving. When you are happy that your workpiece is aligned correctly, turn on the Air Assist and Air Extraction on the power strip.
- Close the enclosure door, put your glasses on, warn anyone else in the room that you are starting the fiber laser and give them glasses to wear, close and lock the exterior door, and cover/put the the sign in the window.
- At this point you should still have the Frame menu open. If not, click Frame again to open the Frame menu. When you are ready to start the engraving, press Start.



Fiber During the Project

- ❑ Keep your laser glasses on at all times, even if the enclosure is closed, while engraving.
- ❑ Stay with the laser while engraving.
- ❑ The door should be locked so no one should be able to walk in unexpectedly. If you forgot to lock the door and someone does walk in, press “Pause” in LightBurn, especially if you have removed the front half of the enclosure. Pressing Pause will allow you to restart at exactly the same position.
- ❑ You can watch your project through the webcam.



Fiber Post-Cut Checklist

- Wait 10-15 seconds for the laser bed to exhaust before opening the door.
- Retrieve object(s) from laser bed.
- Turn off Air Extraction and Air Assist on the power strip.
- If you are done engraving, save your file and close LightBurn and the Camera app.
- Turn off the “Laser” switch on the power strip.
- Replace the front of the enclosure cover if you removed it. Clip the front and back halves together.
- Wipe off the bed by spraying a cleaning spray on a paper towel and wiping the bed.
- Put away any auxiliary parts, alignment jigs, etc.
- Record your time on the laser using the QR code near the laser or the link on the desktop.
- Leave the computer and monitor on.
- Cleanup the room. Set the min-split to 70 degrees.





Additional Resources & Advanced Classes

Questions About Coin Engraving

I want to make coins! How long is it going to take?

- If you're using vector art, it depends on the material, how deeply you want to engrave, and how large the coin is. Budget at least 10 minutes per side for brass, 30 for steel for reasonably deep engravings. The Dude 3D engraved coin took 60 minutes

I want to make a coin that looks 3D. How do I do that?

- You will need to create a depth map, which is a raster image but looks like a ghost of your image. You can take a 3D file, usually a .stl, and convert that to a depth map using online tools such as <https://fenrus75.github.io/FenrusCNCtools/javascript/stl2png.html>
- If you have a .png or .jpg image, you can convert it to a .stl then to a depth map with online tools such as https://imagetostl.com/convert/file/png/to/stl#google_vignette.
- Depth maps are treated as an image, but a different type in LightBurn. Think of it as subtractive manufacturing layer by layer, and it will take 30+ minutes to get a good 3D coin engraving.
- There are paid websites that make it easier to create 3D depth maps. Sculptok, DepthR,

I want to engrave DEEP. How do I do that? And what happens

- High Power (90%), slow to medium speed (500-1000mms), low frequency (20-50), as many passes as you can tolerate the time they take. Use the air assist to clean the surface while engraving. Do a cleanup pass in between every 5-10 deep engrave passes.

What coins should I buy?

- Beware of the cheapest coins on Amazon. They are not always solid single metals. You can end up with a steel coin with paint on top. When you go to polish the coin, you'll find out that they aren't made of one solid material. See other slides in this slide deck for suggestions.

I want to make a lot of coins, how can I speed up the process?

- Use brass or aluminum coin blanks. Wood would be WAY faster. Stainless steel feels substantial in the hand, but it takes a long time to engrave deeply.

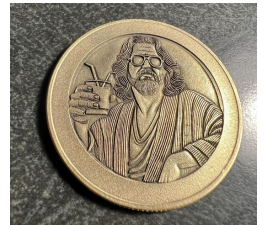

Questions - Cutting Through

Can I cut through metal with our fiber laser?

- Yes.
- Thin metal will work best (<1mm), but you could cut through thicker metal if you are willing to wait, and to take time between passes to allow the metal to cool because the application of the fiber laser (aka heat) to the metal will start to warp the metal as it heats up.
- There are ways to mitigate the warping such as using a heatsink underneath your workpiece. Few people have tried so far and you will need to experiment. Make sure to put a piece of metal underneath your workpiece to avoid cutting into the bed.
- Cutting through can be done using “Fill” engraving. This will take a long time, but will result in less jagged edges and more detail. Example below didn’t get through after 36 minutes of fill engraving but was close.
- Cutting through using “Line” engraving works when the project isn’t too detailed, but leaves jagged edges that need to be sanded/polished. Example below got through with 13 minutes of engraving.
- “Wobble” makes cutting through much quicker, but makes the edges more jagged.

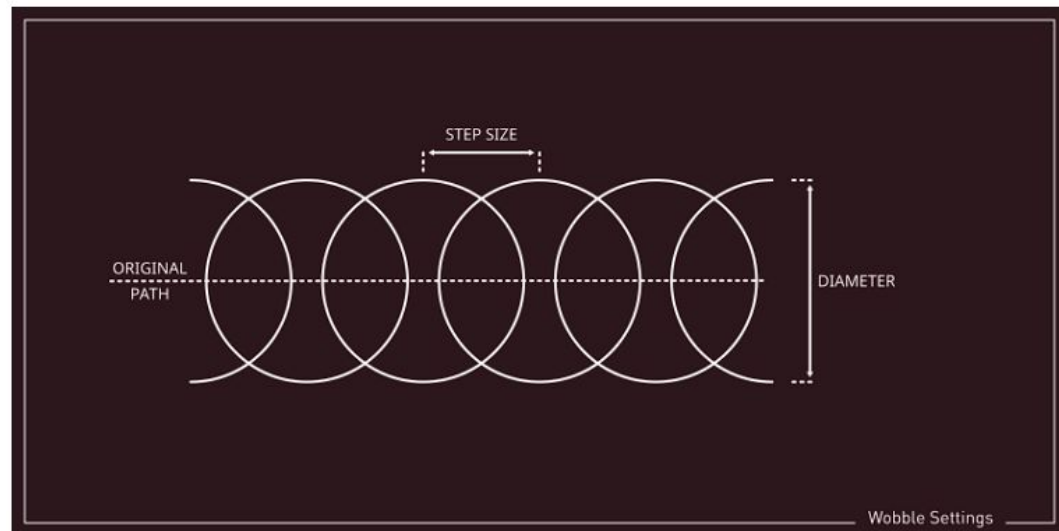

Questions - General

I want to engrave a photo on metal. How do I do that?

- LightBurn treats raster images differently than vector art. The LightBurn image setting you use will depend on the look you are going for. There are lots of choices and lots of online tutorials. Engraving an image on something will take less time than a deep engrave.

I want to mark a steel tumbler/dog tag/hammer/whatever. How do I do that?

- Making a mark on steel is something a fiber laser excels at. You can get a permanent mark on steel without actually engraving deeply into it and it takes very little time to do. A 1"X1" mark on steel can take < 20 seconds to complete. And that mark won't come off anytime soon.

I want to engrave through something that is powder coated/anodized. How do I do that?

- HIGHLY RECOMMEND a few deep engraving passes to get through the coating, followed by a cleanup pass. It will look ugly after the deep engraving passes and look perfect after the cleanup pass.

I want to use LightBurn at home, how do I import the machine settings from our fiber laser?

- The wiki has both the LightBurn config files and fiber laser machine files posted. Load these at home and it will be the same settings as on the computer attached to the fiber laser.

I'm engraving through powder coated items and getting different results?

- Depending on the supplier, the powder coating may be more or less thick and there can be differences in how the laser deals with the pigment in the powdercoat. Recommend running deep engraving passes until you see bright sparks on the pass (indicates the metal is being engraved, not just the powdercoat being blasted away) and then run 2-3 cleaning passes until you are happy with the finish. Then setup both deep and cleaning passes in one layer for further production runs.



Questions - General

I want to anneal/dark mark steel. How do I do that?

- Again, lots of tutorials available out there. There are different power/speed/frequency settings per material type that will give you that dark mark look.

I want my artwork to stand proud of the surface/I want to engrave everything but my image. How?

- In Lightburn, if it's white, it's not engraved. If it's any color, the laser is engraving that area. If you put a solid object (square, circle, whatever) behind your vector image/text, it will automatically invert so that your art or text is white and the engraving will happen around it.

Can I use a .jpg/.png/.gif or other file in LightBurn?

- SURE! But it will be treated very differently than vector art. If you aren't familiar with vector art yet, it's worth doing so because lasers, cnc routers, vinyl cutters, and many other Makersmiths tools utilize vector graphics.

I have a logo I want to use on the fiber laser but it doesn't look right when I import it into LightBurn?

- If you can get the original vector image version, you will save yourself a lot of time and agony. If you can't get the original, you can trace raster images in LightBurn as well as Inkscape, Illustrator etc. Spending the time to get a good vector version of your logo will save you days of effort down the line if you want to do other things with that same logo.

What else could I engrave a 3D depth map on?

- Stones look pretty cool!



Questions about Color Engraving



I want to engrave colors. How do I do that?

- Lots of testing. Color engraving is usually on steel, some aluminum alloys and titanium, and is achieved by heating the material to specific temperatures that create the color.
- You can create different amounts of heat in different ways
 - Experiment with one setting at a time, or use the “Material Test” so that two settings change but you can see the difference.
 - Example - reducing the Q-Pulse setting means that the laser will fire for a shorter amount of time per pulse which equals less heat with all other settings being equal.
 - Example - increasing the frequency setting means that the laser will fire more times per second but at a lower power per pulse, meaning more heat gets applied in the engraving with all other settings being equal.
- Like many videos say, you have to test on each material. My 304 stainless plate with a particular finish may look different from your 304 stainless with a different finish. Test, Test, Test.
- If you only plan to do a one off project in color, you will probably end up spending more on the materials required to dial in your settings than you want to.
- Running the same settings from a LightBurn Material Test on a two different pieces of material cut from the same sheet gave different results. This may be because the material was heated up during the material test, the material was slightly differently focused during the second test due to warping, or something else entirely happened.
- Some sites suggest defocusing the laser when trying to engrave color. Defocusing the laser would have the effect of reducing the heat generated in the center of the pulse/spreading heat more widely in the area of the pulse, and could be one way to apply heat differently to get color. - this would reduce the amount of heat generated by the lase
- Check out this video and watch the videos before and after this one: <https://youtu.be/G0IKDZ3Us7s>.



Fiber Laser Useful Links

- Book your fiber laser time: <https://makersmiths.org/reservations/lasers>
- Lots of fiber laser settings: <https://www.omglaser.com/laser-settings/>
- Makersmiths Member fiber laser settings:
<http://wiki.makersmiths.org/display/MAK/Fiber+Laser+Settings>
- Metal blanks:
 - <https://www.jpplus.com/engraving/blanks/shapes/metal>
 - <https://swissbui.com/> - Coins are \$2-\$4 per piece. Good coins but smaller sizes, lots of shapes and edge finishes.
 - Etsy - \$2-\$6 per piece depending on size, thickness, edge finish, and quantity
 - Amazon - lots of bulk options from outside the US. Some quality issues.
- LightBurn for Galvo Crash Course - mostly about configuration of LightBurn or the https://youtube.com/playlist?list=PLoBR3k35202Yjc1yMfPZsY8EDh_pmcaa2&si=ALTo-ycuzaUfLfva
- Laser MOPA Color: https://youtu.be/-mtg-pmoiOA?si=ANzvetWHZm4_46BE
- Personalized Coins (with some good settings):
<https://youtu.be/uDh832exroA?si=P2ZleoP1xxC1kXP9>
- Lasereverything Fiber Laser Setting Database: <https://db.lasereverything.net/scripts/settings.php> - (as of March 2026 requires an account to be setup).



Cleaning/Polishing Metal

- Metal doesn't usually come out of the fiber laser engraving process ready to use. Some cleaning and polishing is required.
- There are many ways to do this including by hand, using a rotary tool (Dremel), and using a polishing/buffing wheel on a grinder.
- Cleaning and polishing your engraved metal can be done with scouring pads, scouring pads on a Dremel shaft, sandpaper, wire wheels, cloth wheels with polishing compound of different grits on a Dremel or on a grinder, and many other options.
- A 50 pc buffing/polishing set for a Dremel can be as low as \$7.
- A 145pc of Dremel polishing pads is \$7
- A set of 6 polishing compound bars is \$10



Tips, Hints, & Have Fun (cont)

Where to buy Acrylic

- Canal Plastic (closest to us) <https://www.canalplastic.com/collections/acrylic-sheets>
- Johnson Plastics <https://www.jpplus.com/engraving/sheet/laser/plastic>
- Tap Plastics (furthest, longer shipping)
https://www.tapplastics.com/product/plastics/cut_to_size_plastic
- Inventables (great place to buy small sheets of 1/8" wood too. Just double check it is laser safe)
<https://www.inventables.com/categories/materials>



General Laser Links:

- Computer Creationz: https://www.youtube.com/channel/UCB3-k4fmkVqTTjAhb0Cdd_g
- LightBurn Official YouTube Channel: <https://www.youtube.com/@lightburnsoftware7189>
- The Louisiana Hobby Guy: <https://www.youtube.com/@TheLouisianaHobbyGuy>
- 10 Tips and Tricks for Laser Engraving and Cutting
<http://www.instructables.com/id/10-Tips-and-Tricks-for-Laser-Engraving-and-Cutting/?ALLSTEPS>
- Material Safety and your Laser
<http://support.epiloglaser.com/article/8205/30188/material-safety-and-your-laser>
- How to test if a material is safe to laser cut!
https://www.reddit.com/r/glowforge/comments/3no1vj/how_to_test_if_a_material_is_safe_to_laser_cut/
- Visit the Engravers forum at: <http://www.sawmillcreek.org/>
- Laser Engraving Tips: <http://www.inoplas.com/techtips/laserengrave.asp>

Some of the above are more geared towards CO2 than Galvo lasers.



Advanced Classes

We have a rotary attachment and a rotary base for engraving many of the same item which will be taught in a later class.

