

GETTING STARTED  
IN WOODTURNING

# Safety for Woodturners

Selected Readings from *American Woodturner*,  
Journal of the American Association of Woodturners

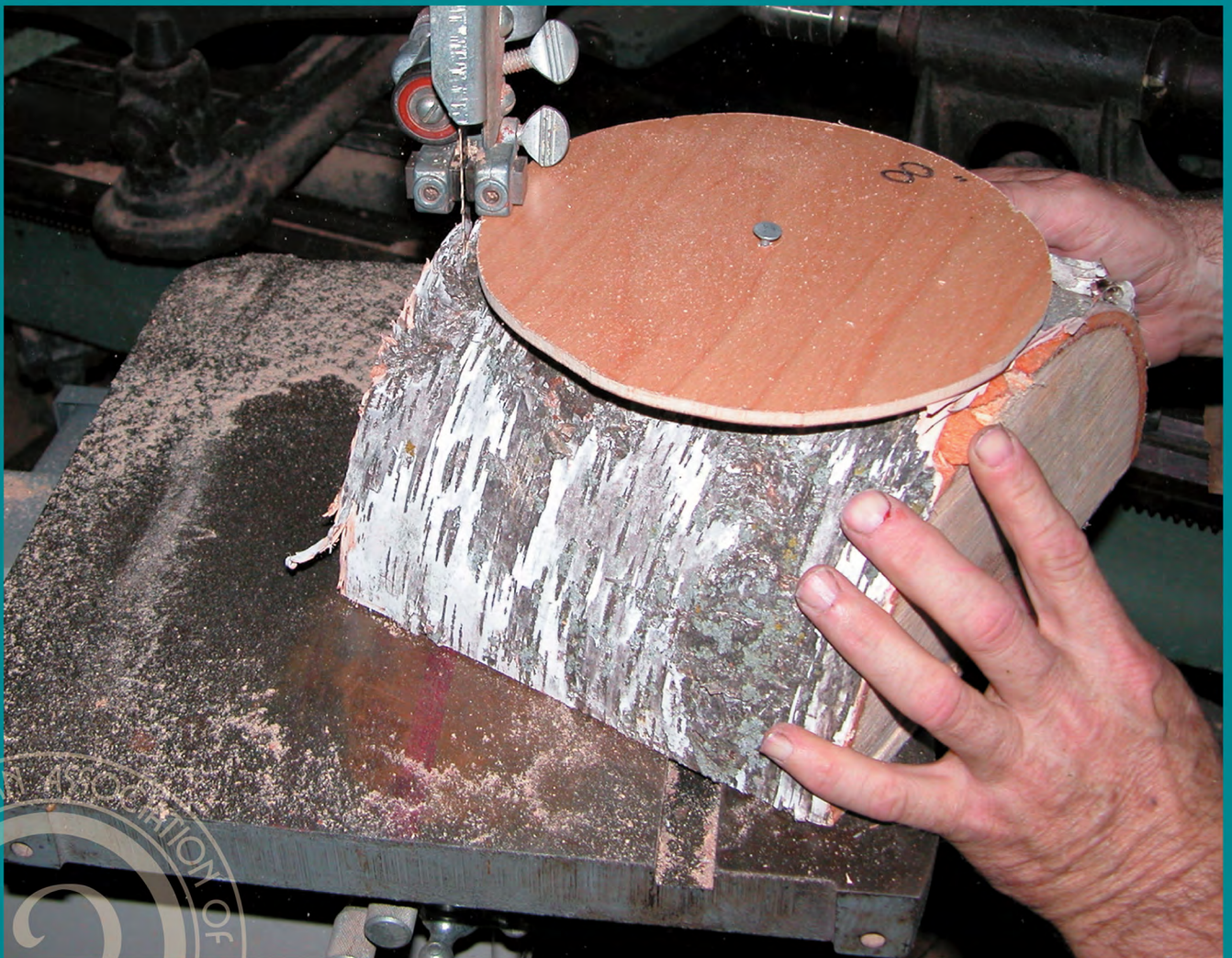

GETTING STARTED IN WOODTURNING

# Safety for Woodturners

Selected Readings from *American Woodturner*,  
Journal of the American Association of Woodturners

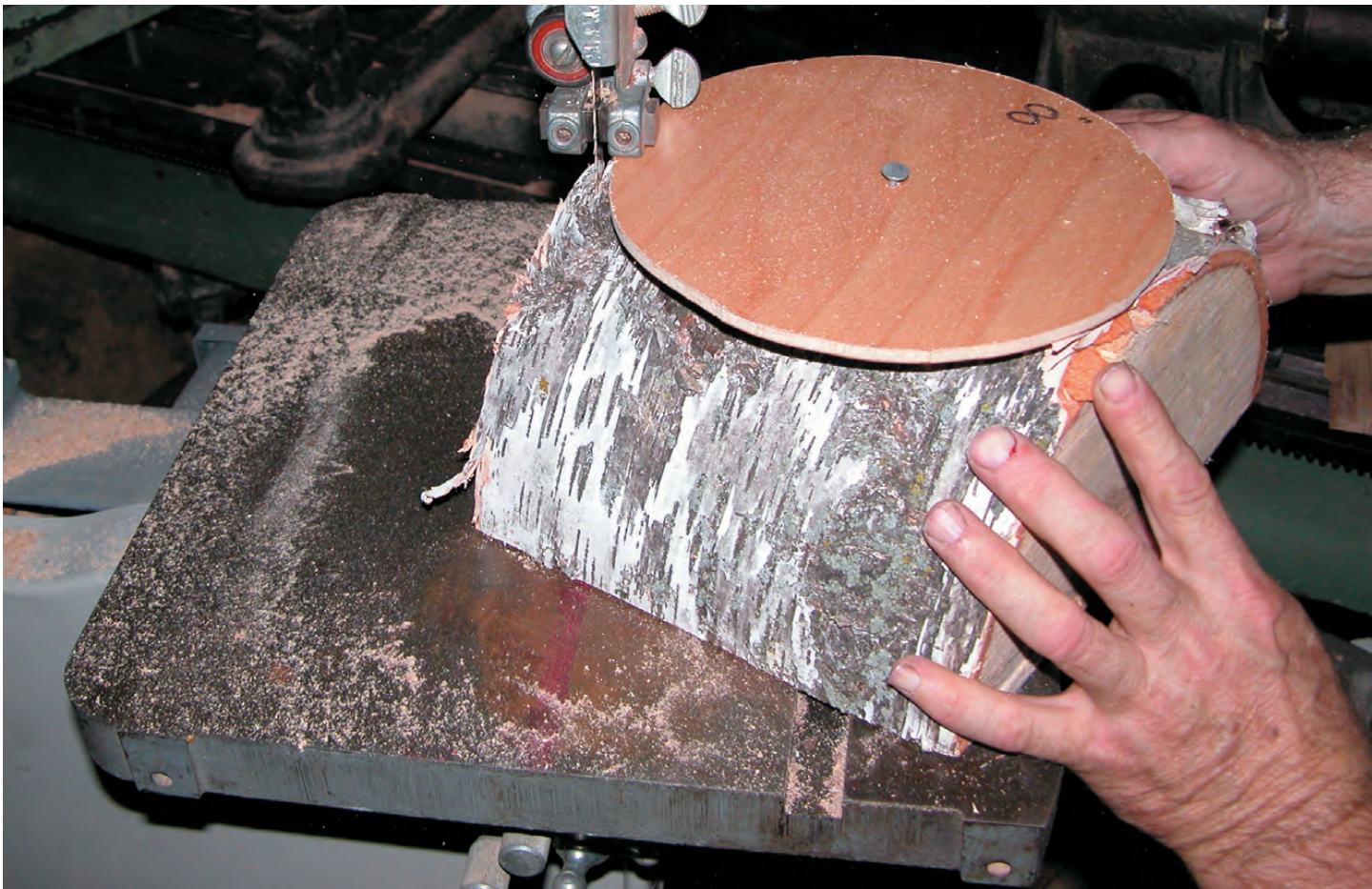

American Association of Woodturners  
222 Landmark Center  
75 5th St. W  
St. Paul, MN 55102-7704  
877-595-9094  
[www.woodturner.org](http://www.woodturner.org)

# Contents



Published by American Association of Woodturners,  
222 Landmark Center, 75 5th St. W., St. Paul, MN 55102-7704.  
877-595-9094, [www.woodturner.org](http://www.woodturner.org).

Copyright ©2013 American Association of Woodturners. All rights reserved. No part of this publication may be reproduced in any form without written permission. Readers may create any project for personal use or sale, and may copy patterns to assist them in making projects. The information in this book is presented in good faith; however, no warranty is given nor are results guaranteed. *American Woodturner* magazine and the American Association of Woodturners disclaim any and all liability.

*American Woodturner* (ISSN 0895-9005) is published bimonthly by American Association of Woodturners.

*Safety for Woodturners*  
ISBN 978-1-939662-00-2

Printed on Demand in United States of America  
American Association of Woodturners, [www.woodturner.org](http://www.woodturner.org)

- 3 **Introduction**
- 4 **Safety for Woodturners: On the Edge of Disaster**  
*Hilda V. Carpenter*
- 8 **Safety Lessons: Hard-Won Advice from the Ozarks**  
*Ron Ufkes*
- 10 **Are You Wearing the Right Faceshield?**  
*Andrew Chen*
- 12 **Checklists for Woodturning Safety**  
*John Kelsey*
- 16 **Safety Lessons: Twenty Ways Not to Turn a Bowl**  
*Nick Cook*
- 22 **Safety Lessons: Twenty Ways to Master Spindle Turning**  
*Nick Cook*
- 26 **Safety Lessons: How to Avoid a Catch**  
*Lyle Jamieson*
- 30 **Safety Lessons: Sharpening Jigs**  
*Jim Rodgers*
- 32 **Safety Equipment: Wood Dust Solutions**  
*John English*
- 38 **Safety Equipment: Collect Dust at the Lathe**  
*The Editors*
- 42 **Bandsaw: Safe Setup and Operations**  
*Keith Tompkin*
- 48 **Bandsaw: Safe Practices with Green Wood**  
*Alan Lacer*
- 53 **Chainsaw: Safety Gear, Safe Operations**  
*A. J. Hamler*
- 56 **Chainsaw: Best Practices for Bowl Hunters**  
*Mike Mahoney*
- 58 **Chainsaw Safety: A Stand for Sawing Blanks**  
*Jerry Markowitz*
- 60 **Fitness in the Woodturning Shop**  
*Howard Peters*
- 62 **First Aid for Woodturners**  
*R.W. Waddell, T.S. Meade Jr., C.A. Rula*
- 64 **How to Be Prepared**  
*Dennis Belcher*

# Introduction

If you are reading this book, you have already made an excellent decision to learn more about various ways of turning wood safely. Not only does this involve gaining an understanding of what the likely hazards are, but also developing a work practice and mindset that routinely allows the turner to recognize potential hazards, minimizes the chances for accidents or injuries to occur. These best practices enable the woodturner to incorporate safe techniques into every aspect of how we work with wood, both on and off the lathe.

This excellent collection of articles from the AAW's flagship publication, *American Woodturner*, provides a range of examples of how using safe practices could and should become part of every turner's basic skill set. Reviewing these articles carefully and following the advice recommended will enable you to minimize (...but not eliminate!) the chances for injuries or accidents occurring. Constant safety vigilance is a necessary part of how every turner must approach the practice of woodturning.

Every woodturner goes through a learning curve of acquiring the knowledge and skills needed to accomplish different turning methods. It is our hope that with the publication of *Safety for Woodturners*, a basic understanding and awareness of the need to turn safely will become second nature to every woodturner who reads it, and that all safety-aware turners will fully experience the enjoyment and thrill of woodturning, accompanied by increased confidence in one's abilities, and the comfort knowing that you are doing everything possible to maximize your safety.

Turn SAFELY!

Rob Wallace,  
Chair, AAW Safety Committee  
February 2013

---

## Selected Readings from *AW Journal*

From its founding in 1986, the American Association of Woodturners has published a regular journal of advice, information, and good fellowship for everyone interested in the field. Led by a series of dedicated editors and board members, the *AW Journal* has evolved to become *American Woodturner* magazine, now published in full color six times each year.

The *AW Journal* is a genuine treasure-trove of practical, shop-tested information written by woodturners for their fellow woodturners. *Safety for Woodturners* is the first volume in an on-going series being extracted from this archive. *Safety for Woodturners* is available as a 64-page printed book, or as a PDF download that is readable on all your electronic devices.

Safe woodturning is fun woodturning. A little time spent with this book will help you build strong skills at the lathe while teaching you best woodturning practices.



# Safety for Woodturners: On the Edge of Disaster

Hilda V. Carpenter

While working in our shops, we woodturners sometimes tempt disaster. The very nature of standing in front of a lathe with a hunk of wood balanced between two points spinning anywhere from 300 to 4,000 RPM, attacking it with a hunk of strong steel is, naturally, anathema to safety.

Knowingly or not, woodturners take risks, with danger right under their noses (literally). Last year, after losing Joan Gilmer, a talented, experienced woodturner, safety came to the forefront at the AAW symposium, where all demonstrators were required to wear faceshields. Many demonstrators talked about the importance of safety. Even when uncomfortable using microphones under their faceshields, they persevered to send a signal to all of us woodturners that safety is paramount.

However, eye protection and faceshields are the tip of the iceberg of turning safety, as I found out after interviewing more than thirty-five

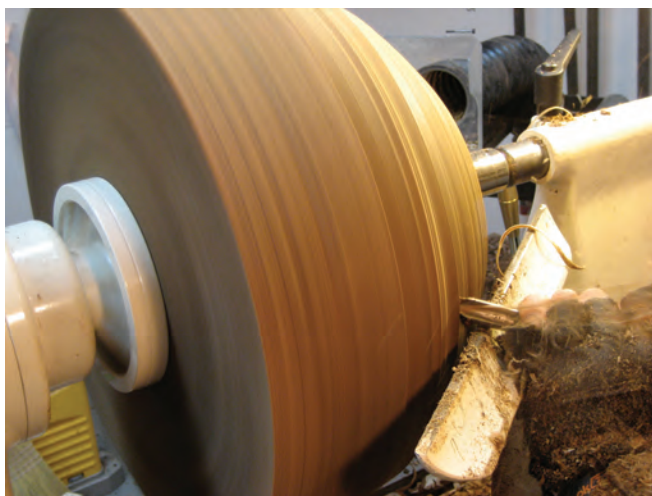

A safe way to turn a large bowl: The wood is solid and is securely screwed to a faceplate. The toolrest is positioned close to where the cutting action is happening, the tailstock supports the spinning wood, and the turner is using a bowl gouge (not a spindle-roughing gouge). Note the ample light.

Photo: Joshua Friend

woodturners from the United States and New Zealand. These woodturners had several horror stories that I term *blow-ups*. I asked the turners to share their experience with the less experienced turners—or to experienced turners who may get careless.

After analysis, these stories fall into four general categories: (1) flaws in the wood, (2) chuck failure, (3) tool misuse or failure, and (4) beginner/mentor failure. The list is not com-

prehensive, nor could it be. We are ingenious after all—someone is going to think of a new, unique way to cause harm. Some stories were comical; some were downright scary.

Three additional categories provide general safety measures all woodturners should employ.

## Wood flaws

It is noteworthy that the wood failure stories included both professional



This faceshield is inexpensive, lightweight, and easily adjustable. It will fit any head or face and glasses can be worn underneath it. The plastic is replaceable.



This wood is punky and may have hidden cracks. For safety's sake, discard it and use wood that you know is solid.



Because of a crack in the wood, a platter split in two while being turned on the lathe. Half of it lodged in the wall near the student.

and hobbyist turners. The comical sight of a hunk of wood sticking into the wall is like a “Wile E. Coyote and Roadrunner” cartoon. The only thing missing is the ACME rocket logo.

With any living organism there will be flaws. In the case of wood, flaws are sometimes readily apparent; sometimes they are not. The key is to be on the lookout for cracks or grain changes. A large crack may be apparent to the eye; however, less obviously, small fissures are where the danger lies. To an untrained eye, cracks and flaws can appear to be part of the grain pattern.

A classic storyline developed: As the woodturner refined the form, a crack—already in the wood or caused by the turner—is present. The turner did not stop the lathe to regularly check the soundness of the wood. High speed combined with either a catch or taking too big a cut caused the wood to fly apart or out of a chuck. The worst horror story I heard was about a crack that gave way as a platter spun at a high speed. The largest chunk hurled through the air and imbedded into the wall, just missing the turner’s face. The smaller piece remained in the chuck. When asked if he saw the crack ahead of time, he replied, “Yes, I was a little worried that I might be getting into trouble, but I had no idea that the crack went as deep as it did.”

Cracks that appear insignificant on the surface of the wood can run deep into the middle. Beginners are at risk for not knowing this. They are often not yet able to tell the difference between a crack and grain pattern. If you are unsure, use a magnifying lens or ask a more experienced turner’s opinion of the soundness of the wood. If the wood is cracked to begin with, discard it and select a sound piece.

Will pouring CA glue into a long, large crack suffice? I would not bet my right eye on it, but for small surface cracks, that glue works well. Be sure, though, that the crack is only a surface event.

Throughout the turning process, periodically check the progress of your work to make sure you have consistency of wall thickness and know how deep you are cutting into the bottom of a bowl or vase. A too-thin area in the wall can render the entire form weak and prone to explode with the slightest catch. And, we all know what happens when we cut through the bottom of a bowl—funnel shards can be lethal.

Punky, soft wood does not hold well when fastened in a four-jaw chuck. Neither does cracked wood.

Gnarly, unsound wood *can* be successfully turned, but only if you know proper methods of stabilizing it while it whirls around, attached to the lathe. Unless you are familiar with those methods, use sound wood. Wood is far less expensive than repairing damage to your body.

### Chuck failure

Chuck failure can be a creeping, hidden disaster waiting to happen. This seems so simple, yet danger can be avoided. Chucks need to be used properly and regularly maintained. Ensure that the chuck is securely screwed onto the lathe’s spindle. (For faceplates, use the setscrew, if available.) With the lathe in reverse while sanding, a chuck (or faceplate) can unwind and fly off the lathe all too quickly. That nightmare came true for a couple of turners who had not checked to make sure their chuck was fastened tightly.

Chuck jaws can come loose. Check the hex screws that hold the jaws in place. These screws, even slightly loose, will create shimmies or wobbles in the turnings that can cause an out-of-balance piece of wood to fly loose at high speeds. Turn at slow to moderate speeds and if a wobble is detected, determine the source and fix the problem before turning up the speed dial.

The design of the tenon that holds a bowl blank into a four-jaw chuck should be such that the tenon does not bottom out in the chuck. The shoulder of the chuck squarely paired with the shoulder



Secure your chuck (or faceplate) onto the lathe’s spindle either by hand or use a mallet if you are not strong enough to push it tight. I use the mallet method, which I learned from one of the older turners.



Tighten the hex screws that attach the jaws to the body of the chuck.

of the tenon will provide a safe hold when combined with a tenon diameter that closely matches the diameter of the chuck jaws.)

### Tool misuse or failure

I was surprised at the number of turners who had tried a tool with no instruction on its proper use. Of course the dreaded skew chisel topped the list. As sharp as they may seem, skew chisels need to be truly sharp. A dull point or edge will cause the turner to push harder than necessary to make the tool cut. When a dig-in happens, the kickback is an equal, opposite reaction, throwing the tool out of the wood. For the most part, the wood suffers the damage, but the tool itself can become a rocket. Take light cuts with skew chisels. If a light cut is not making shavings easily, sharpen the

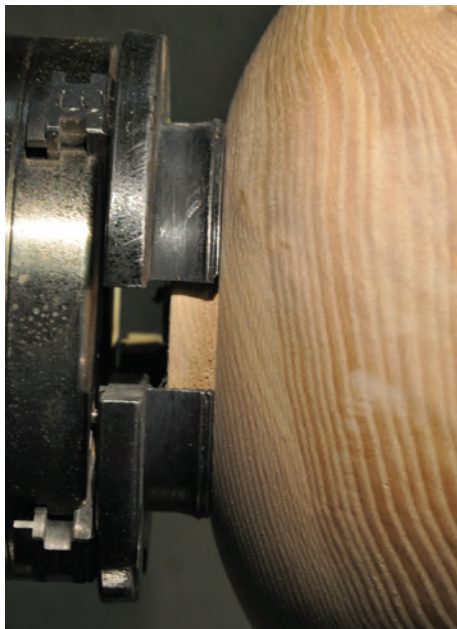

Make sure the bottom of the tenon does not bottom out in the chuck and that the shoulder of the chuck rests on the shoulder of the tenon.

tool. Get instruction on the proper use of your skew chisel.

The bedan, detail gouge, parting tool, and even faceshield appeared in stories from both inexperienced and experienced turners. One turner literally burned the wood because her parting tool was binding on the sides of the cut. That could have been easily fixed, but the more serious concern was the embers that fell into the wood shavings at her feet, starting a fire. She was wearing a heavy-duty, air-helmet faceshield so she didn't smell the smoke right away. Her husband happened to come into the shop, saw the smoke, and grabbed some nearby water to put out the fire.

In the case of the bedan, the question is *which side is up?* A bedan can help create smooth finishes, as well as assist in turning beads and coves. It also is a good tool for creating tenons. But this tool is relatively new to most turners, so instruction on its proper use is not widespread. In one case a turner was creating a tenon on a thick piece of wood for a spindle turning. Two things happened that fell in line with other bedan stories. First, he had the tool upside down to perform such a function. Next, the bedan

became trapped in the wood, spun under the toolrest, and hurt his hand. Unfamiliar tools can end up as ceiling fixtures—ACME rockets come in a variety of designs. Learn their proper use from an experienced turner.

Scrapers. I use them on my bowls. Improperly used, they can cause major dig-ins. While finishing an eight-inch bowl, using a scraper on the inside to smooth the surface, one woodturner did fine with the side walls. When he went to finish the bottom, however, he failed to reposition the toolrest. With the tool hanging too far over the toolrest, a severe catch happened, jerking the scraper out of his hand. Airborne, the tool imbedded itself into a wood rack behind him. He has never stuck a scraper into the bottom of a bowl again. Unfortunate, because scrapers, when used properly, are quite safe: Bevels of scrapers do not touch the wood when scraping or shear scraping. The toolrest should be positioned as close as possible to the wood and still have the shank resting solidly on it.

By *tool failure* I mean that the actual tool failed. For instance, creating your own tool handles is an inexpensive way to personalize tools, but a ferrule should be part of the handle and should also fit properly. Ferrules help keep the tool shank safely lodged in the handle. If a tool were to be caught between the toolrest and the piece of work, a properly fitting ferrule can save the day. Most of the stories of flying wood fragments included skipping adding the ferrule when making the handle.

Other stories included turners who had setscrew handles and either the setscrew came out, or became loose. The steel would either spin or move in or out of the holder. Periodically inspect the tightness of setscrews—they can become loose with turning.

### **Beginning turner/ mentor failure**

If you agree to teach another turner what you know, especially if he or she

is a beginner or new to the tool/technique you are offering, you are assuming a responsibility of safety for both of you. Know your own limitations and do not offer instruction if you are not prepared to assume the safety of your fellow turner.

I received countless stories where accidents occurred when a turner was teaching someone else a technique. In one case, an experienced woodturner of more than thirty-five years was working with someone to help him refine his bowl turning. The mentee became distracted and the tool flew out of their hands, right into the mentor's abdomen. He showed me his scar.

For the mentors, stand clear of the less experienced turner while he or she turns. The target area is adjacent to or in front of the turner, so stand to the side and let the mentee learn through hands-on practice. Stop the student occasionally to reinforce positive techniques. If the student experiences a catch (and they will), this is an opportunity to reenact the event and then correct the wrong technique. The reenactment can take place with the lathe off while the student calms his nerves.

Teach the ABC's of turning: anchor, bevel, and cut. Anchor the tool to the toolrest, acknowledge the bevel, and begin the cut slowly. For this to make sense to beginners, make sure the student understands that the bevel supports the cut, especially at the beginning. The cut can then take place with a greater assurance of safety.

The student and instructor/mentor should both wear faceshields.

If you are attending a class or workshop with other turners, make sure you are aware of your surroundings. You might want to position your lathe slightly out of line of the person behind you. And remember that you are a student—let the instructor take care of your neighbor who does not understand a technique.

If you have never used a particular tool, ask for help from someone who you know is knowledgeable.

Woodturning is a rewarding pastime or profession. Teaching woodturning to others is equally rewarding. The stories indicate that the teacher and the student will both learn a lot from the time together, so take advantage of expert help whenever you can.

### Sharp tools are safe

A dull tool can skip or cut the wood inappropriately, catching the turner off guard. When a tool is dull, the turner will apply more muscle to make it cut. Let the tool do the work—pushing harder does not replace sharpening a tool or learning its proper use. Check the sharpness of a tool by scraping the cutting edge against your fingernail or across a soft piece of wood; it should leave a mark. If it does not make a scratch, it is too dull. If a tool is not cutting easily, sharpen it.

Learning how to properly sharpen your tools is well worth the time invested. Take a class at one of the many schools for woodturning (they are all listed on the AAW website at woodturner.org). Buy a good DVD on sharpening and practice. You will have a lot more fun and discover there is more in the turner's bag of tricks than 60-grit abrasive.

### Faceshields and dust protection

Select a faceshield that fits your head securely and is easily adjustable. For turners with large heads, make sure your faceshield is far enough away from

your face so that it does not fog up. I went through three manufacturers' faceshields before finding one that had knobs that would adjust to fit my small head. Then, when you buy that perfect faceshield, buy several replacement visors and change them often to keep your vision clear.

A turner's faceshield is as much of a tool as any that cuts wood, but be aware that a faceshield is only a last line of defense. Faceshields are not capable of taking the full brunt of a large chunk of wood smashing into your face. I am not aware of any studies that have been conducted on the extent to which faceshields protect from flying chunks of wood or rocket tools, so do not lure yourself into thinking that other safety measures can be ignored simply because you conscientiously wear your faceshield.

The negative affects of wood dust *are* cumulative. At the very least, wear a properly fitting dust mask. Better yet, wear an air-circulating dust helmet/faceshield and install a dust collector in your shop. Change or clean the filters regularly. Those tiny, seemingly insignificant airborne "rockets" are potentially lethal.

### Miscellaneous

There were many other stories about drill presses, CA glue and accelerator, epoxies, lacquers, bandsaws, and chainsaws. However, of all the turners I spoke with, not one said that their blow-up stopped them from grabbing

another piece of wood from which to make their next masterpiece. Not one professional teacher said they intended to stop teaching and demonstrating.

Only one turner claimed, "I've never had a blow-up." I repeated this to several experienced woodturners and asked their opinion. They all skeptically said: "That guy is either lying, or he doesn't really turn." Perhaps it really was true, but the point is that mistakes do happen—safety awareness and practice are every turner's defense against getting seriously, or critically, hurt.

Consider including in your local chapter's newsletters reminders about safety and short stories about members' blow-up episodes, along with the lessons learned. New turners appreciate this information and experienced turners need reminders.

Lastly, newbie or experienced: Woodturning is live-on-the-edge fun and can be safe. You are the primary factor in staying safe, so follow your instincts. If your gut feeling tells you something might not be safe, pay attention. Armed with an understanding of proper techniques and safety, you can be assured that your tools and wood will *not* become ACME rockets.



When using a scraper on the inside of a bowl, make sure the toolrest is as close as possible to the surface being cut. You might even want to use a curved toolrest. Use plenty of light.



This tool handle is not safe. Include a ferrule when you make your own tool handles so that the wood will be supported near the shank of the tool. For this tool handle, which was turned too small for the available ferrule, I will attach a small hose clamp.

---

*Dr. Hilda V. Carpenter began turning three years ago. At a SWAT symposium she attended Binh Pho's demonstrations. Shortly after, she purchased a Robust lathe and fell in love with turning, carving, and airbrushing. Hilda is a retired professor and Executive Coach and now lives in Texas.*

*A special thank you to Stephen Hatcher, Binh Pho, Graeme Priddle, the online forum of World of Woodturners, and all the clubs, professionals, and individuals who participated in interviews.*



# Safety Lessons: Hard-Won Advice from the Ozarks

by Ron Ufkes

**D**uring the August 2002 meeting of the Ozark Woodturners Association, someone commented on a bandage I had on my hand and rudely asked what had happened. After I told him, a couple of others spoke briefly of injuries that they had suffered over the years.

A few days after the meeting I received an email from a newer member who said that he had learned more from the discussion of our safety lapses than he had from any of the other demonstrations we had given. With that in mind our president, Steve Ramsey, decided that the October meeting would be given over to safety lessons learned the hard way and that each member would be asked to describe injuries they had sustained or near misses from which they had gained a lesson in safety. Below are the stories as told at our October 19, 2002, meeting. They are edited and paraphrased, but are substantially as told by the members.

- Paul said that he had been told that holding a wire in a groove around a turning would make an attractive dark ring around the workpiece. What he had not been told was that the wire is an excellent conductor of heat and before he knew it he had also burned a dark groove in his hand. He has since learned that wooden handles must be attached to the wire. The handles will help avoid a severe cut if the wire should be seized by the rotating workpiece. Never, ever make loops on the ends of the wire and try to hold the loops with your fingers, as that would be an excellent way to lose a finger.

- Joe #1 commented that if you use a wire without handles to burn a groove, “it seems like you can’t hardly get rid of it fast enough.”

- George #1 cautioned against sticking your hand into a spinning bowl because of the danger of getting caught. He also noted that even if you use a push stick to push a piece of wood through a table saw, you should not use your left hand to guide the piece. Believe it or not, if your thumb slips, the saw will cut it, he said, as he held up his thumb. Feather boards are a great assist here.

- George #2 said that he was carving on a bowl when his wife called him for dinner. He was cleaning off the bottom of the bowl with a chisel and as he held it in his hand and hurried to finish up, the chisel slipped and cut into his palm. He wrapped it in a paper towel and secured it with duct tape (good for almost any problem), ate dinner, and then went to the emergency room for three stitches. The doctor commented that it was a nice clean cut.

- Bob said that while we think of steel as being tough, a 3/8-in. gouge that he was using to drill a depth hole caught and broke into several pieces that flew in different directions. He also told the members that if anything other than cutting is to be done to wood on a lathe, it is very important to remove the tool rest first, because sandpaper, a cloth or steel wool can be caught so quickly that it and the fingers holding it can be pulled into the space between the workpiece and the tool rest, and could easily result in the loss of or injury to the fingers.

- Ron passed two pairs of glasses around, noting that the spots of polyurethane, when dried, cannot be removed from plastic lenses. However, he had found that acetone will remove CA glue from some plastic lenses. While acetone is a powerful solvent and will destroy some plastics, his optometrist had cleaned the glue off without damage. He warned, however, not to let the acetone run to the edge of the lens where it could get between the frame and lens. Apparently the coating on the lens prevents damage to the plastic, but consult your optometrist before you try this, because all lenses may not be the same type of plastic. His main point was that it is absolutely necessary to wear eye protection at all times while doing any lathe or other machine work: had he not been wearing glasses, the CA glue would have gone into his eyes. The lesson is that if you value your eyes you must wear eye protection, a face shield over shatterproof safety eyeglasses.

- George #3 pointed out that when using CA glue to fill a void of any depth, the accelerator will harden the glue on the surface like a scab, but the glue underneath may remain liquid for a long time. If you begin turning too soon and turn off the surface, the uncured glue beneath will be flung out by the rotation of the piece and into your face if you are not wearing your face shield.

- Bob cautioned that the C in CA glue is cyanide, and that a dust mask should always be worn when sanding any exposed CA glue.

- Ron also told the members that after removing a piece from the scroll chuck, it is a good idea to remove the T-bar or tommy bar before turning the lathe back on. He said that it was important, as stated in the manual, that the jaws of the scroll chuck not be opened so far that the slide extends past the outer edge of the chuck body. If you do, the jaw pieces will fly out. He also noted that the large diameter three-jaw machinist chucks work well, but the jaws may protrude out so far that they are liable to strike the user's hand if he is not very careful and this mishap definitely will take a chunk of flesh away. Several members nodded at that.

- John ran a tool off the end of the workpiece and into the four-jaw chuck. He said he lost the tool, some skin, and a piece of the chuck itself. More members nodded.

- Joe #2 said that he failed to use a push stick and ran his hand into the blade of his band saw. His doctor in the emergency room told him that sooner or later, everyone suffers an attack of severe stupidity.

- Ray recently glued up three 20-in. 2x6s to make a housing for a light-house lamp. He clamped everything and trued it all up, cut the corners off the end, and carefully mounted the assembly on the lathe. After checking the tailstock to be sure it was tight. He turned on the lathe, but had forgotten to check the speed. He didn't say what the speed was but it must have been very high. The workpiece came apart and became so out of balance that it whacked the cast-iron tool rest and broke it off at the base. Delta wanted \$92 for a new base. The group agreed that he had been lucky to get off so lightly.

## Devote a Meeting to Safety

The Ozark Woodturners is a small club of about 38 members, 21 were present for the safety meeting and of the 18 with stories to tell, 6 had sustained injuries serious enough for a trip to the emergency room. I know of two additional injuries that needed emergency treatment: a finger broken, and a finger requiring eight stitches (mine). In a group of macho guys, these stories produced a lot of laughs over the stupid things we had done, but as I wrote this article, I realized that these injuries and near misses were not funny at the time. It was sobering to think of the pain suffered (especially mine) from incidents that were all preventable. I suspect other turning clubs would have similar results from such a meeting, so I'd urge each club to devote one meeting to a discussion like this and see for yourselves. There is a real danger of very serious injuries if we don't keep our heads up and pay attention to what we are doing.

- Mike said that one hazard was forgetting to raise your face shield before spitting. More seriously, he told of cutting his thumb on the band saw only a week earlier. A member asked Mike to describe the ceiling of his shop. He dismissed this, saying that the visible holes were only from some explosions (he works a lot of manzanita). He also admitted to having lost a few fluorescent lights.

- Ed said he had been pretty fortunate. He threw a blank off his lathe and the piece flew out of his shop and hit the barn about 100 feet away. Luckily he was standing out of the way. He warned the members that if they hear any unusual noise while turning, stop and check it out before continuing. And don't be in the line of fire.

- Bob said that he was turning a vase and as a challenge to himself he made it as thin as he could. It was so pretty and so thin that he really liked it, but he wasn't sure that the rim was quite smooth enough. He checked it with his finger and cut himself on the rim—it was sharp as a knife.

- Moe was turning a 4-in. alabaster bowl and had it sanded and ready to finish with French polish, which he normally does with the lathe at high speed. He had forgotten that alabaster expands with heat and as he was apply-

ing the polish the bowl exploded and flew all over the shop. Fortunately he was standing off to the side and didn't get hit. The moral of the story is that when using alabaster or talc, turn at a low speed and keep the material cool because otherwise it might come apart.

- Steve said that years ago he read an article about inlaying wire into a groove in the wood and securing it there with CA glue and then turning off the rough surface of the glue. He thought it was a good idea. He said what happened next was not really his fault (yeah right Steve) because the author of the article had not said that the tool might catch the end of the wire and tear it loose. At about 450 RPM, the loose end of the wire caught him across the back of the hand several times before he could jerk it away.

- Finally Ron asked if any other members had ever punched little holes in their elbows because they had left the sharp pointed center in the tailstock while doing faceplate turning. Several hands went up. It is always comforting to know that you are not the only one that sometimes does stupid things.

---

*Ron Ufkes lives in Lakeview, Arkansas, and is secretary of the Ozark Woodturners Association.*

# Are You Wearing the Right Faceshield?

Andrew Chen

For woodturners, faceshields are important safety equipment, so much so the AAW requires demonstrators to wear one while demonstrating at the annual symposium. That is not the case everywhere. Last November, I was invited to do a demonstration at the Taiwan Association of Woodturners in Taipei, one of the newest AAW chapters. I was not able to bring a faceshield, and I requested one. I was disturbed when they handed me the “faceshield.” Similar to the one in Photo 1, it had a thin clear plastic shield reinforced with an aluminum rim—not the adequate protection I was used to. Fortunately, though, I was turning a goblet out of 2" (5cm-) square wood and the flying debris would probably not cause the shield to fail. I thought this was a good opportunity to educate the audience, primarily consisting of new turners. It also made me wonder how many AAW members were cognizant of various types of faceshields.

## Different types of shields

There are many different types of faceshields designed for various purposes. All turners probably know not to use a welder’s faceshield or the type a dental hygienist wears, but do you know what kind of faceshield is good for your protection while turning? The type I used in Taiwan is a splash shield designed for chemical (liquid) splashes. Its thin plastic shield is not strong enough to protect, even from medium-sized flying wood objects. The aluminum rim merely supports the flimsy plastic to help hold its shape. The metal rim actually presents a greater hazard because if the plastic is shattered, or simply deflected by a

flying object, the aluminum can be forced into your face, which is exactly what happened to a couple of members of our club a number of years ago—the aluminum ended up in their cheeks causing severe lacerations and a trip to the emergency room. Even so, some stores that cater to woodturners and woodworkers carry this type of faceshield. If I had not known about the injuries suffered by my fellow turners, I might have bought one.

## Correct faceshield

The correct type of faceshield woodturners should wear is the thick polycarbonate (PC) shield without the metal rim (Photo 2). Testimony to that came from another member of our club who is known for turning large projects (20-plus inches [50cm] in diameter). These massive mesquite root balls have defects and bark inclusions, and at last December’s meeting, he reported that a large chunk of bark inclusion flew off a mesquite turning and broke his faceshield. Fortunately he came through unscathed physically—he was wearing a thick polycarbonate faceshield. The faceshield was a loss, but it did its job.



1 A splashguard-type faceshield is not suitable for woodturning protection.

These thick PC faceshields are widely available for about \$15. When purchasing a faceshield, make sure it is rated Z87+ (Photo 2, insets) as opposed to just Z87. Although it is an improper way of labeling, sometimes you will find Z87.1 instead of Z87+. These ANSI (American National Standards Institute) ratings are primarily designed for eye protection.

Although the standards were revised in 2010, standards for faceshields did not receive substantive revision from the 2003 guidelines, which basically stipulate that lenses will be divided into two protective levels, basic impact and high impact, as dictated by test criteria. Basic-impact lenses must pass a “drop ball” test: a 1"-diameter steel ball being dropped on the lens from 50 inches (127cm). High-impact lenses must pass a “high velocity” test where ¼" (6mm) steel balls are shot at different velocities. For faceshields, that’s 300 ft/s (~205 mph, 329 km/h). Thus, the high-impact (Z87+) standard requires the faceshield to withstand more than five times the kinetic energy of the basic-impact standard (Z87) (4.41 joules vs. 0.84 joules).

## Powered respirator

Instead of a simple faceshield, some turners prefer a powered air-purifying respirator (PAPR), such as the 3M Airstream (Photo 3) or Trend Airshield (Photo 4, Pro model shown). In addition to protection from flying debris, these PAPRs provide lung protection by filtering out wood dust. A PAPR is my personal favorite because the filtered airstream also prevents condensation on my glasses and on the faceshield from my breath.



2 This faceshield has a thick polycarbonate shield. Note the impact rating in the inset images, basic impact, Z87 (upper left) and high impact, Z87+ (lower right).



3 The 3M Airstream powered air-purifying respirator. Photo: Paul Millo



4 The Trend Pro model powered air-purifying respirator. Note the ANSI Z87.1 label, inset image.



5 Even though this faceshield is rated Z87+, it may not offer as much impact protection as one with a thicker shield.

A word of caution: Although the Airstream and Airshield are rated high impact, the window (visor) on these faceshields is only about half as thick as the Z87+ non-PAPR faceshields (0.04" [1mm] to 0.045" [1.1mm] vs. 0.08" [2mm]). You can actually deflect the thin plastic window by applying moderate pressure with your finger. On the Airstream and the Airshield (original), this window is reinforced with a frame made of a type of plastic other than PC. The Airshield Pro has just a steel wire at the bottom for reinforcement. Knowing of possible failure of thinner shields with reinforcement, one should be leery of PAPRs.

Some faceshields, like the one shown in Photo 5, also have a thin visor mounted in a frame. Even though it

has the Z87+ rating, it may not provide the same level of protection as the thick PC faceshields.

### Faceshield standards caution

There are two disturbing facts about the Z87.1-2003 standard. First, it eliminated the previous requirement of a minimum thickness of 2mm (0.08") on the protective lenses. Second, in the United States, compliance with the standard is self-certified, based on test results generated by the manufacturer as part of its initial design and ongoing quality-control procedures. No independent certification is required. Therefore, although I wear a PAPR personally, I would caution their use.

This article is not an exhaustive review of all faceshields on the

market—it simply points out the danger of using the wrong type of faceshield and provides basic information for selecting the proper woodturning faceshield. Faceshields provide some protection; however, consider them a last line of defense. A catastrophic explosion of a large turning could still overwhelm your faceshield. It is essential to practice the basic safety precaution of staying out of the line of fire (plane of rotation) as much as practicable. In addition, when you restart the lathe with a turning that has previously been chucked onto the lathe, recheck to make sure the chuck jaws still secure the wood, or check the screws if you use a faceplate. And, start at a lower speed when turning large, unstable wood.

# Checklists for Woodturning Safely

John Kelsey



**Felled by flying wood**  
That's how this blockhead was found, after he ignored the Woodturning Safety Checklists.

**W**oodturning is safe, until something goes wrong. Accidents at the lathe happen incredibly quickly, and woodturning accidents can be lethal. Yes, lethal.

That's tough talk, but think for a moment—you would be hurt and you could be killed if a heavy chunk of rotating wood were to fly off the lathe and smash into your face. It has happened to others and it could happen to you. That's why good woodturners take responsibility for their own safety by internalizing a safety point of view. Your attitude is your first line of defense, with faceshields and other protective gear the backup system.

And that's why safe turners, like airplane pilots, run down a checklist before hitting the "ON" switch, and they pay close attention to working safely while the chips are flying.

The risks include:

- Body parts battered by airborne wood flying off the lathe. Most dangerous: irregular and unsound wood.
- Nasty cuts from dropping sharp turning tools on unprotected feet.
- Violent injury if loose hair, jewelry, or clothing were to catch on the spinning chuck or workpiece.
- Fingers crushed under dropped wood, made worse if you're wearing rings.

- General mayhem if the turning tool was wrenched out of your hands because it tangled with the workpiece before you got it firmly planted on the toolrest.
- Nose and lung damage from inhaling fine dust. Wood dust, sandpaper detritus, grinder debris—all bad.

Woodturners are at risk when using bandsaws, chainsaws, and power carving tools, so it's essential to learn and follow safe practices for that equipment too. But that's another story—this one's about how to prepare and protect yourself at the lathe and how to avoid turning mishaps.

## Attitude Checklist: Your Sharpness

### 1. Stay alert.

Understand the Danger Zone. Pay attention to unusual sounds or vibrations; stop the lathe to investigate the cause. And yes, it is dumb to operate machines when you are tired or under the influence of drugs or alcohol.

### 2. Workshop.

Plug your lathe into a grounded outlet, no extension cords. Keep your work area well lit. Don't set up in wet locations. Mount a fire extinguisher beside the exit door.

### 3. Lathe.

Keep your lathe in good repair and develop the habit of scanning it for damaged parts, misalignment, or binding parts. Listen for unusual sounds. If you detect something amiss, deal with it immediately, before continuing your project.

### 4. Stance.

Stand like a soldier, easy but firm with your feet comfortably apart, shift your feet to maintain solid footing and keep your balance. Your stance powers all turning cuts. If you use an anti-fatigue mat, make it big so you can't trip on its edge.

### 5. Tools.

Learn what tools to use for each task, and keep tools sharp and clean. Forcing a dull tool invites a mishap, so pause often to touch up the cutting edge.

### 6. Know thyself.

Know your capabilities and limitations. An experienced woodturner can handle lathe speeds, techniques, and procedures that are not so smart for beginners to attempt.

## The Danger Zone

The Danger Zone is the space directly behind and in front of the workpiece. This is the red zone or firing zone, where the workpiece would be most likely to travel if it were to fly off the lathe.

Don't be in the Danger Zone when you first turn the lathe on, and keep your hand on the switch while the motor revs up, in case you need to turn it off fast. When observing someone else turn, stay out of this zone. When turning irregular, unbalanced, and unsound wood, train yourself to keep your head out of the Danger Zone.

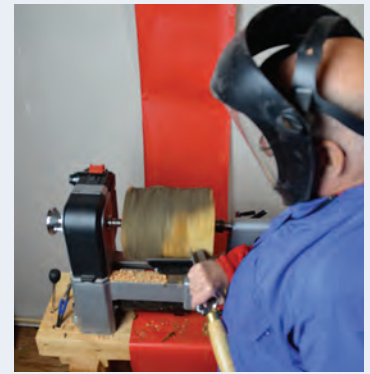

### Well turned-out

Essential safety gear includes shatterproof eyeglasses, comfortable faceshield, and turning smock. Many turners prefer a rolling cart for organizing tools and keeping them at hand.



### Tune your lathe

Keep the lathe bed clean, rust-free, and waxed, so the tailstock and toolrest slide freely.



### Tools

Learn to sharpen efficiently, so you will sharpen often.



**Eyes, face, body, lungs**

Safety glasses with side shields, faceshield, dust mask that fits. Tight shirt cuffs. Long hair tied back...lol.

**Personal Protection Checklist: Every Time You Turn**

**1. Eyes and face.**

Wear a full faceshield all the time. If you also wear eyeglasses, get shatter-proof lenses with side shields.

**2. Body.**

Wear a turning smock with short sleeves or tight cuffs. Tie back long hair, and avoid loose clothing, dangling jewelry, or ear-bud wires that could catch on the lathe, chuck, or workpiece.

**3. Lungs.**

Wood dust, sandpaper debris, and fine particles from a grinder will harm your respiratory system. Ventilate your workshop and wear a dust mask or air filtration helmet, or install a dust collection system.

**4. Ears.**

Wear hearing protection during extended periods of turning.

**5. Feet.**

Wear closed-toe shoes or work boots, never sandals, to protect your feet from dropped tools and chunks of wood.



**Ears**

Band-style earplugs can be worn with a faceshield.



**Feet**

Don't wear sandals in the workshop. Wear sturdy closed-toe shoes.

**Lathe Checklist**

**1. Lathe bed.**

Clear turning tools, setup tools, materials, and coffee cups from the lathe bed.

**2. Headstock and chuck.**

Remove and stow chuck keys, adjusting wrenches, and knockout bars. Form a habit of checking for these before switching ON. Also check to be sure the belt guard or cover is in place.

**3. Tailstock and toolrest.**

Use the tailstock to support the workpiece whenever possible. Check that all locking devices on the tailstock and toolrest assembly (rest and base) are tight.

**4. Sanding and finishing.**

To protect your fingers, always remove the toolrest before sanding, finishing, or polishing operations on the lathe. Apply finish with small scraps of cloth or paper towel, not large rags, and stand aside to avoid flying droplets.

**5. Full stop.**

Never leave the lathe running unattended. Turn the power OFF. Don't leave lathe until it comes to a complete stop.



**Lathe bed**

Get all this clutter out of your way. Build a handy rack or cart to store all your turning tools and accessories.



**Headstock and chuck**

Check for chuck keys and stow them before switching ON.



**Tailstock and toolrest**

Raise the rest to center height or just below. Tighten everything. Lock the tailstock quill.



**Sanding and finishing**

Move the toolrest out of the way, or remove it entirely, before you sand or finish.

## Checklist

### 1. Clearance.

Rotate the workpiece a full turn by hand to be certain that it clears the toolrest and bed before turning the lathe ON. If it's possible to use the tailstock for support, do it.



#### Clearance

Rotate the workpiece completely by hand to be sure it clears the toolrest.

### 2. Chuck and faceplate.

Grab and push the workpiece to be sure it's firmly seated in the chuck jaws. When using a faceplate, be certain the workpiece is solidly mounted with stout steel screws (#10 minimum).



#### Chuck and faceplate

Push and shove the workpiece to be sure it's firmly seated in the chuck. For faceplates, use stout steel screws, not drywall screws (they are brittle).

### 3. Reversing.

When running a lathe in reverse, securely tighten or lock the chuck or faceplate on the lathe spindle so it can't unscrew and fly off.



#### Reversing

Lock the chuck to the spindle so it can't fly off.

### 4. Speed.

Always check the speed of the lathe before you turn it on. Use slower speeds for larger diameters and rough pieces, and higher speeds for smaller diameters and balanced pieces. When the workpiece is unbalanced, start slow. If the lathe shakes or vibrates, slow it down. If the workpiece vibrates, stop the machine to find out why.

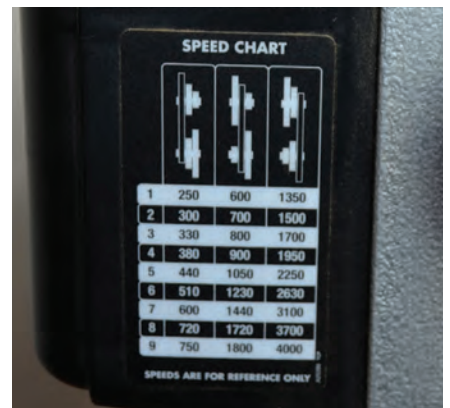

#### Speed

Start slow. With rough, unbalanced wood, start slower.

### 5. Unusual wood.

Wood with cracks, splits, checks, bark pockets, knots, irregular shapes, or protruberances could fly apart on the lathe. Beginners should stick with sound wood. Start slow and keep your head out of the danger zone until you balance the piece and assess its soundness.

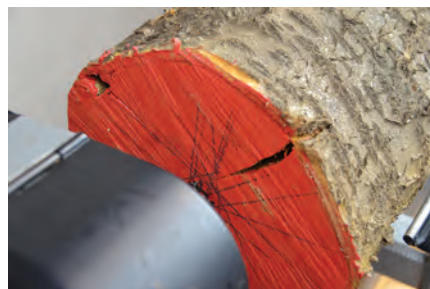

#### Unusual wood

Deep cracks and checks could be trouble: the wood might fly apart. Stand to the side and start slow.

### 6. Toolrest.

Hold turning tools securely on the toolrest, gripping the tool in a controlled but comfortable manner. Always plant the tool on the rest before you allow it to contact the workpiece. Turn the lathe OFF before you adjust the toolrest or toolrest base.



#### Have fun!

Emerging artist David Earle enthusiastically made the shavings fly at the AAW's San Jose symposium in June 2012.

### 7. Have fun!

You'll enjoy turning the most when you're confidently on top of safety.



# Safety Lessons: Twenty Ways Not To Turn A Bowl

Nick Cook

When it was suggested that I write this article, I wondered if it was because someone thought I didn't know how to turn a bowl. I was assured that I drew this assignment not because I'm inexperienced at bowl turning but rather because I have had so many woodturning students.

I have been teaching woodturning for more than 20 years, and many of the classes have been basic, for beginners, or an introduction to woodturning. You can ask anyone who has been involved in one of these classes and they will tell you that my most frequently used direction is: "Stop, don't do that!"

Anyone who teaches basics at John C. Campbell, Appalachian Craft Center, Arrowmont, or Anderson Ranch Craft Center expects to have raw beginners in a class. We also expect novices with just a little experience and even expect a few who have been turning for a number of years.

The teacher's challenge is getting all of the students on the same page in the same book at the same time. Adult learners seem to have their own ideas about how to turn, and some are not the least interested in how I want them to turn. Some are self-taught; some have attended other classes. Others



Photos: Marris Pruss

No matter how eager you are to turn your first "keeper," don't begin turning with large or expensive stock. The 8"-diameter stock on the headstock is more appropriate.

have read woodturning books and watched videos.

And others... must have been time-traveling to their eighth-grade shop classes when someone was attempting to instruct them.

## The right stock

One of the biggest problems teachers face is that many students are itching to turn a really large bowl the first time they step up to the lathe. Or, they lug in something that cost them big bucks.

## Stop! Don't do that!

**1 Too big.** You will learn a lot more about turning techniques by turning lots of small, shallow bowls than you ever will by turning one or two really large pieces.

**2 Too valuable.** Whatever you do, do not pay for practice wood. There is plenty of free wood out there—the stuff really does grow on trees. Ask around at your AAW chapter; you'll find a resourceful group with plenty of practice pieces.

**3 Too hard.** Green wood is a great way to start. Wood lots and local tree cutters are great sources for practice materials.

**4 Too deep.** Start out with a small (8"-diameter) platter before attempting any type of bowl. When you are comfortable with that, transition to a shallow bowl—just slightly deeper, but still about 8" in diameter.

Keep the form open rather than making the openings smaller. The smaller the opening, the harder it is to cut the interior.

**5 Not ready for prime time,** (or finish). Don't worry about applying finish to anything—that will come later. Think practice pieces. I suggest that you use a screw chuck or faceplate and turn shapes that resemble bowl forms until you get to the point of becoming comfortable with the bowl gouge. When you get to where you do not have to think about what the tool is doing, you are ready to turn a bowl. Once you get a few decent-looking forms, turn the bowl around and begin hollowing the interior. Then, get out the finish.



## The right speed

Too often, novice woodturners go from turning spindles to turning bowls without adjusting the lathe speed. Too big and too fast is a deadly combination.

## Stop! Don't do that!

**6 Too much speed.** Before mounting stock between centers or on a faceplate or chuck, switch on the lathe without anything mounted. This will give you the opportunity to see where the speed was set when the lathe was last used. Developing this habit will prevent an accident.

I encourage students to reduce the speed of their machines at the end of every turning session. This is easy on variable-speed lathes, but I meet resistance to this when students are learning on machines with step pulleys. Do it anyway; it's never too early to develop good safety habits.

**7 Too much of a hurry.** Another problem that can ruin your day occurs when you have a large piece on the lathe and stop the machine too quickly. This happened to my

friend Andy Marinos, who suggested adding this tip to the Don't Do! list.

To turn the bottom of a bowl, Andy mounted his large flat jaws on his scroll chuck and mounted the rim of the bowl in the jaws. Without checking the speed, he turned on the lathe. It was going much too fast for the task at hand. Andy quickly hit the stop button on the machine, and the motor stopped. But, the chuck and the bowl had enough momentum to keep spinning—even with the lathe stopped. When it came off the spindle, the assembly caught his hand between it and the tool rest. Andy's wound required numerous stitches.

Here's a safer plan: Start the lathe at a low speed or use the setscrew in the chuck to lock it onto the spindle.

**8 Standing in the wrong place.** You should always stand to one side of the workpiece (out of the path of the spinning blank) when you turn on your lathe as shown in the photo *above*.



**Bowl Gouge—Yes!**

**Skew—No!**

**Spindle Roughing Gouge—No!**

Here's a classic example. One student mounted a large, square blank on a lightweight lathe and turned it on at too high of speed. Needless to say, I screamed from across the room, "Stop, don't do that!" When I got to where he was working, I also discovered that he was about to attack the piece with a 1¼" spindle roughing gouge. Oh, and it wasn't sharpened yet; it had just come out of the box.

You should not use the skew on a bowl either!

**10** **Big gap at tool rest.** One of the most common problems is extending the tool too far out over the tool rest. Many times, students will continue cutting without moving the rest any closer to the blank. Once the tool extends more than 1" or so beyond the rest, stop the machine and move the

As your bowl takes shape, stop the lathe frequently and move the tool rest to about 1" from the stock.

The bowl gouge, top, is the only one of the three lathe tools you should use for your bowl projects.

### The right tool

Before anyone stands in front of a lathe, I review all of the tools, their uses, and how to sharpen each. I identify each tool, explain how it is used, show how to sharpen it, and also show the various cuts that can be made. I also explain what each tool is not designed to do. But sometimes, that's not enough.

### Stop! Don't do that!

**9** **No roughing-out gouge for bowl work.** For bowl turning, never turn with a roughing gouge. This should be a no-brainer, but I have seen it done. In my mind, this tool should be referred to as a spindle roughing gouge.





When turning the outside of a face-grain bowl, turn from the bottom to the top (sometimes described as uphill).

tool rest closer. Lathe tools have been known to break over the tool rest—a very bad thing.

The height of the tool rest is determined by the tool you are using and your height and stance. Always place the tool on the rest first, touch the back of the tool to the blank, then gently lift the tool handle until the bevel makes contact with the wood. This will ensure the bevel supports the cutting edge. You will be less likely to get catches this way.

**11 Moving tool rest with lathe running.** Don't even think about it! Never move the tool rest with the lathe running.

**12 Not following the curve.** It is not uncommon for a beginner to make straight cuts



along the length of the tool rest, correctly move the rest closer but continue to cut in a straight line. To produce better profiles, move the tool rest around the shape of the bowl. The result is a cone-shaped bowl. This is where a curved tool rest can be helpful, although not a necessity.

Work on a continuous curve—not thinness.

**13 Wrong direction.** For face-grain bowls, cut uphill or from bottom to top on the exterior of the bowl. On the interior of your bowl, cut downhill or from the rim to the center.

**14 No body movement.** You are not bolted to the floor. To produce better curves, use your body and move it through an arch. Learn that “woodturner’s sway.”

When you remove stock from the interior of a face-grain bowl, always begin at the rim and work toward the center (also described as downhill).

Place the tool handle against your hip and hold the handle with your right hand near the shaft and your left hand on the tool rest. Keep your left hand on the tool rest throughout the cut to provide additional support. Remember, if you move your feet, you move the pivot and lose the curve. Learn to swing your body, but don't move your feet.

**15 Dull tools.** Beginners also have a problem determining whether a tool is sharp or not. It takes experience to be able to tell. Different woods react differently to being cut. Most beginners merely increase pressure as the cutting edge gets dull. This can be dangerous.

When in doubt, sharpen the tool. And, the best way to sharpen a tool for beginners is with jigs and fixtures; they all work, and they all provide excellent results. Hand-sharpening also works after you learn what you are doing, but the jigs and fixtures will provide consistent results each and every time.

Be sure to touch up your edge on the grinder before making your final cut. A dull tool will pull or tear at the fibers, leaving a surface that you can't sand smooth. This is especially true on end grain.

Each instructor will show you his or her favorite grind for the bowl gouge. They all work if you take the time to learn how to use them. It is more important that you learn to consistently reproduce the grind you are using than which profile you choose.

Grinding by hand is important to learn, but for the beginner, jigs and fixtures are a great help.

**16 Too much pressure.** Another common problem is applying too much pressure when



A grinding jig helps many new turners repeat the same bevel on a lathe tool.

cutting the surface. This will force the heel of the tool into the surface and bruise the fibers, leaving lines that remain invisible until you apply finish. Yikes!

These lines are almost impossible to sand away. You must recut the surface. Relax and let the cutting edge do the work rather than forcing it.

### The right mount

A lot of bowl-turning problems begin with how the material is attached to the lathe. Because every new lathe is shipped with a faceplate, this is the obvious choice for the beginning woodturner.

### Stop! Don't do that!

**17 Wrong screws.** Trouble can begin at the first step when you screw the blank to the faceplate. Here, several problems can occur. It usually starts with drywall screws; they are too thin and too brittle. You exacerbate the problem when you draw up dry-wall screws with a power screw-

driver, which pulls them up tight and snaps them.

Sheet metal screws are a better choice to attach turning stock to a faceplate. These screws are case-hardened and have deeper and sharper threads. Make sure you choose a length that is appropriate. Square-drive screws are also popular and are much easier to remove from hardwood.

For securing turning stock, one size does not fit all. For an 8"-diameter blank that is up to about 2" thick, I recommend #8×¾" screws. For a 14×8" blank, secure with #14×1½" hardened screws.

**18 Difficult grain.** You must also consider the material you will be putting the screws into. End grain requires larger and longer screws. Beware of punky or spalted woods; once the wood has started to decay, it is extremely difficult to get a screw to hold.

Sapwood does not hold screws as well as heartwood. To be on the safe side, bring up the tailstock with a live center for insurance. This will give additional support if the screws do not hold.

Choose turning stock that offers a better chance for success. Dale Nish says it best: "Life is too short to turn crappy wood!"

**19 Poor grip.** Once you get excited about turning, it probably won't be long before you purchase a 4-jaw scroll chuck, which I think holds material better on the lathe. However, this chuck has its own set of challenges.

I have had many instances where students have made tenons too small or the recesses too shallow. Either case can cause the blank to separate from the chuck.

Punky wood and sapwood present the same challenges and grain problems as noted *above*.

**20 Loose fit.** Green wood requires you to tighten the jaws of the chuck repeatedly as moisture is forced from the blank. Just as with the faceplate, remem-



If you want your bowl to stay in the chuck, you'll learn the value of properly sizing the tenon. If the chuck loosens, the bowl will fly off the lathe.

ber to use the tailstock and center whenever possible.

Turn safely and have fun. But by all means, think about what you are doing and consider the risks involved. If you are unsure, ask someone with more experience. If it looks dangerous, it probably is.

"Stop, don't do that!"

---

*Nick Cook (nickcook@earthlink.net) is an American Woodturner contributing editor. Nick, who lives in Marietta, Georgia, will teach afternoons in the Youth Turning Room at the AAW symposium in Louisville.*



Sheet-metal screws should be your only choice for mounting turning stock to faceplates. At *right*, you can see how a drywall screw can break off, which leads to huge safety issues.

# Safety Lessons: 20 Ways to Master Spindle Turning

Nick Cook

*In the hands of an expert, turning a spindle looks effortless. But there are plenty of pitfalls to avoid on the journey to expertise. Here are 20 tips to help you become a spindle master.*

Spindle turning may seem easy for production turners and others who have stood in front of a lathe for a few decades. Many of us simply turn on the machine, mount the blank between centers, and start cutting. Those who watch—either in demos or as students and even clients—are amazed at the speed and accuracy with which we perform what we consider the mundane task of turning spindles.

But for the beginner, there are so many things to think about!

Let's start with mounting the blank. Should we use a safety center or a spur-drive center? A two- or four-prong spur center? Should I use a mini-spur? Should it be spring-loaded or not?

See what I mean? This may be too much for the average student.

Most beginners don't really have to think about all that much. The lathe they just purchased came with a drive center and a four-prong spur center without a spring loaded center, and is large enough to drive most anything that will fit on it.

Here are some do's and don'ts to improve your spindle work.

## Mount your stock

**1 Choose your turning stock carefully.** Avoid knots, checks, and other defects. Straight-grain blanks produce the best results. Poplar is inexpensive, easy to turn, and readily available. For projects requiring detail, maple is my favorite light-colored hardwood; walnut and cherry are ideal when dark woods are preferred.

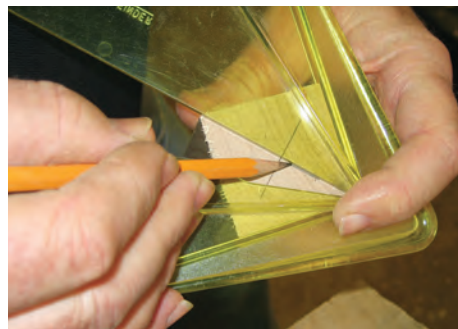

**2 Always use a centerfinder or a straightedge across the corners of the blank to find the center.** This is especially true if you are going to leave squares on the final turning. It is also necessary to make sure the blank is truly square when preparing the material. On fully rounded work, this is not as critical.

**3 Never mount the blank with the lathe running.** It is dangerous and can cause you harm. Don't do that!



**4 Never drive the blank onto the spur center while it is mounted in the spindle.** This can damage the Morse taper and stress the lathe bearings.

Photos: Marisa Pruss

AW 21-4, p46

## Tool-rest tips



**5 Never drive the spur center into the blank with a steel-faced hammer.** This will damage the Morse taper, preventing it from fitting properly. Always drive the spur with a wooden mallet, dead blow, or other soft-faced hammer.

**6 Never apply excessive pressure on the blank with the tailstock.** Slide the tailstock forward, lock it in place, and run the live center into the end of the blank. Be sure to lock the quill in place once you've snugged up the tail center. At the tailstock, use a good-quality live or ball bearing center; one with interchangeable tips to accommodate different applications is worth the extra expense. A cup-shaped tip on the live center will be less likely to split smaller blanks.



**7 Maintain your tool rest.** All turning tools are harder steel than the tool rest. Nicks and dings in the tool rest will be reflected in the workpiece. Use a mill file to keep the tool rest smooth. Some turners even wax the tool rest with paraffin (sometimes called canning wax).



**8 Position the tool rest parallel to the blank and as close as possible— $\frac{1}{4}$ " is adequate clearance.** Be sure to lock the tool rest to the support and the support to the lathe bed. Always rotate the workpiece by hand before turning on the machine. No matter how many times you have seen it done in demos, never move the tool rest with the machine running. Always move the tool rest closer after removing the corners from the blank—excessive overhang of the tool will cause chatter.

### Popular tailstock centers

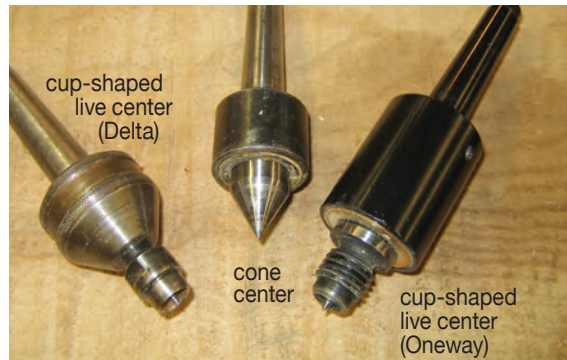

### Popular drive centers

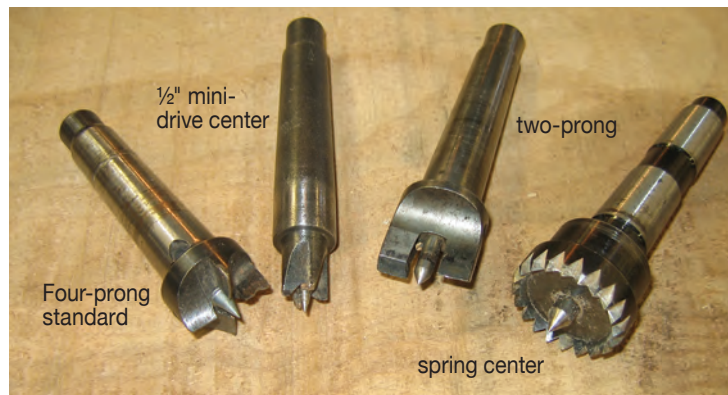





**9** Adjust the height of the tool rest to match the tool you are using. You should cut above center for most lathe tools. If you switch from a thick tool (like a spindle roughing gouge) to a thinner tool (like a skew) you will need to raise the tool rest.

### Turning tips



**10** Always cut downhill, from large diameter to small diameter on spindles. Attempting to cut uphill on some woods will produce disastrous results—expect a lot of catches.



**11** Never work with dull turning tools. If in doubt, sharpen the tool. The skew in particular needs to be razor sharp. Honing is required to maintain the edge of the skew; other tools may be used straight off the grinding wheel. Sharpening jigs or fixtures will ensure that you get a consistent bevel angle on your tools. (See page 30 for details.)



**12** Never turn on the lathe without first checking the speed. Step pulleys are easy to check visually. Variable-speed lathes that utilize an adjustable pulley system do not allow you to change the speed without the machine running. Turn on the lathe before mounting the blank, adjust the speed, then turn it off and mount the workpiece. Some of the electronic lathes are equipped with digital read-

outs so you can see the RPM as you make adjustments.

Here are speed guidelines (wood species and experience are key variables): For 1" - to 3"-diameter stock, I recommend roughing out at 1,200 rpm and moving up to 2,000 rpm for finishing cuts. For stock 5" in diameter or larger, rough out at 800; finish at 1,500.

**13** Use your body—not just your hands—as you move the tool along the tool rest. This will provide more support and better control.



**14** When turning furniture parts or architectural elements with square ends or pommels, make sure your blanks start out perfectly square. It is also critical that you accurately locate the centers on this type of work.

## Master skills

**15** **Take your time;** rushing through a project will probably create less than satisfactory results.

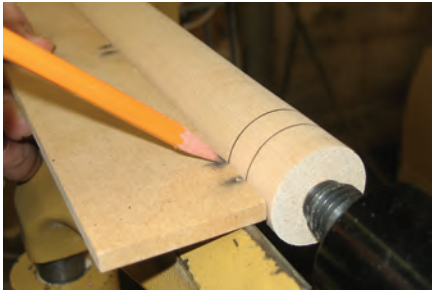

**16** **If duplicating two or more spindles, make a pencil gauge or story stick.** Use your template to mark each blank once it is roughed out. The marks will identify where details are located along the spindles. Use a parting tool or bedan and a vernier scale to cut down to the appropriate diameters. Always measure from the same end to provide consistent results.



**17** **Vernier scales and spring calipers can get caught in the workpiece and snatched from your hands.** Always round over the tips of your measuring tool before using them on spinning stock. Or even safer: Stop the machine to take measurements.



**18** **For additional support and better control** of your spindle turning, wrap your index finger around the tool rest.



**19** **Remove the tool rest prior to sanding.** It's too easy for fingers to get caught between the tool rest and the turning stock.



**20** **Never use cloth rags for applying finish,** only paper towels. In an instant, the spinning lathe can grab a thread and your finger. It's false economy to use cast-off T-shirts if doing so leads to a trip to the emergency room.



## Always think SAFETY!

Whatever you turn, keep two safety tips in mind:

- Always wear a proper dust mask while sanding.
- Never turn without proper eye protection.

Enough said.

*Nick Cook (nickcook@earthlink.net) is an American Woodturner contributing editor. He lives in Marietta, Georgia.*

# Safety Lessons: How to Avoid a Catch

Lyle Jamieson

*If you've been around the AAW for a decade or more, you may recall "Five Ways to Avoid a Catch," a well-read journal article Lyle Jamieson wrote in 1996. Lyle has revisited this topic with fresh drawings and thoughts to take you beyond the suffocating fear of catches.*



To hollow "Class Act" and similar sculptures, Lyle Jamieson uses a supported boring bar. "If you set up a supported system parallel to the floor, you can't get a catch," he said. On his lathe, Lyle hollowed this 20x6x5" elm piece on three axes.

It seems simple, but there are complicated forces taking place while you shape a revolving piece of wood with your turning tools. I want to simplify the process and put a language to catches. If you understand what causes a catch, you can eliminate the cause.

There are just four cuts in all of woodturning: push cut, pull cut, scrape, and shear scrape. Let's further break down these cuts into two groups:

- The push and pull cuts require bevel support to prevent catches.
- The scrape and shear scrape require that you don't violate the 90-degree rule. More about that later.

## Start with sharp tools

A primary way to prevent catches is to turn with sharp tools. A sharp tool can shear off those end-grain fibers cleanly and smoothly. However, a dull tool will push, grab, and tear out end-grain fibers. You can have all the right techniques and still have trouble with catches if your tools are not sharpened properly and often. Sharp tools mean less sanding, and I don't like to sand. Who does?

When using gouges and doing the push and pull cuts, most

catches come from allowing the gouge to cut while not being supported by the bevel. Without bevel support, the tool will dig in violently in a split second. Big chunks of wood are ripped away.

The bevel prevents the gouge from cutting too aggressively—it is a controlling factor.

## Inside the bowl

Let's first focus on the inside of a bowl. This is where catches are most apt to occur because the inside of a bowl is where we are prone to lose bevel support.

The direction the gouge wants to cut is along a line from the heel of the bevel to the sharp point of the edge, as shown in **Drawing 1a**. The first approach is to relax and let the tool go where it wants. Relax the tool-rest hand and direct the cut by moving the handle hand. You can get pretty good at white knuckling your way through a cut, as shown in **Drawing 1b**, but the surface left behind will need a lot of sanding.

It is not much fun when a catch ruins the shape you intended. Relax, take a deep breath, and let your handle hand do the work.

## How to hollow the inside of a bowl

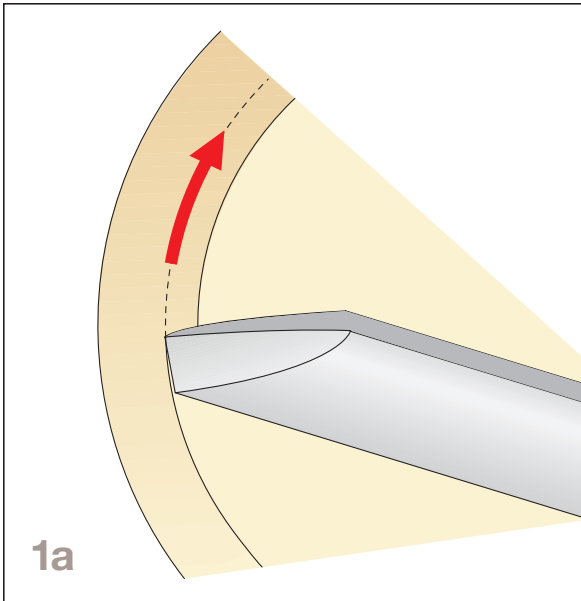

### SAFE

Note the arrow indicating the direction the tool wants to go. Swing the handle slowly toward your body to direct the bevel to travel the path indicated by the dashed line.

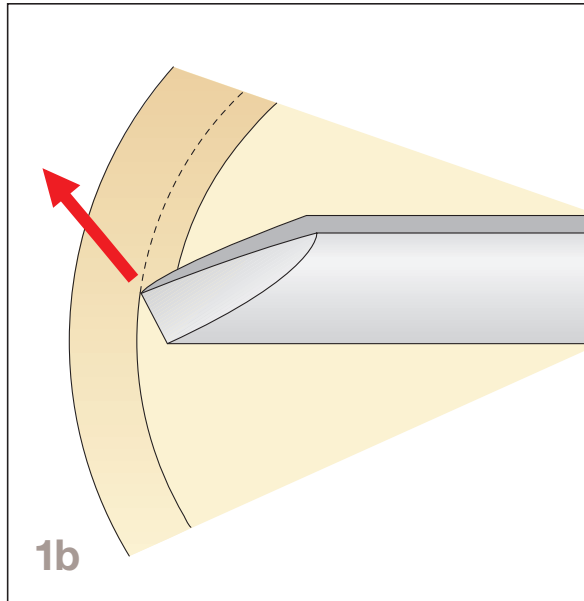

### RISKY

Note the arrow indicating the direction the tool wants to go. Swing the handle slowly toward your body to direct the bevel to travel the path indicated by the dashed line.

### Find the sweet spot

You will hit the sweet spot for a clean cut with the flute pointing in the direction you want to travel with your cut. A twist of the tool will have the flute pointing at a 45-degree angle. Whenever possible, maintain this shearing cut to cleanly slice through each grain fiber as it spins past your tool. Your gouge cuts the shaving at the tip of the cutting edge, as shown in **Photo 2**.

This may help: Think of the motion of an ice cream scoop scooping out the inside of the bowl. You have one hand on the handle of the ice cream scoop and then follow the shape of the rounded scoop for your ice cream.

With the bowl gouge, you follow the little tip of the tool, or the bevel. Swing the tool handle to follow the contour of the vessel with the bevel.

“Ride the bevel” is the usual term to describe this, but it is a terrible

term. You don’t want to ride the bevel, you need to follow it gently. Riding the bevel too hard will cause a number of problems: It will burnish the surface, create vibrations, and bounce the bevel into any voids in the vessel. For me, a “bevel-supported cut” is better.

### Bevel-supported cut

One of the hardest things to accomplish is to start a bevel-supported cut. The tool wants to skate in a spiraling manner across the face of the wood when you start at a 45-degree angle.

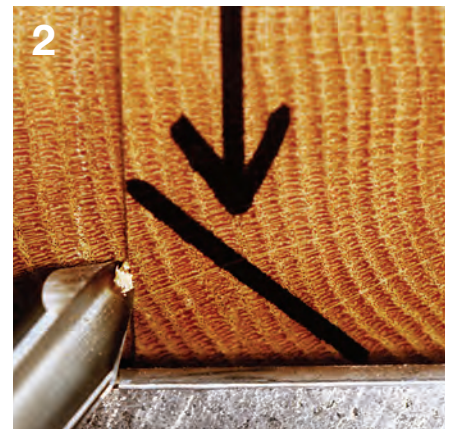

Note the arrow indicates the direction the wood is traveling past the tool. The 45-degree angled line shows the angle that will produce a clean slicing cut. To get this angle, twist the tool on its axis with your handle hand. The shaving comes off the right-hand side at the tip of the tool.

## Starting a cut: Here's a safer way

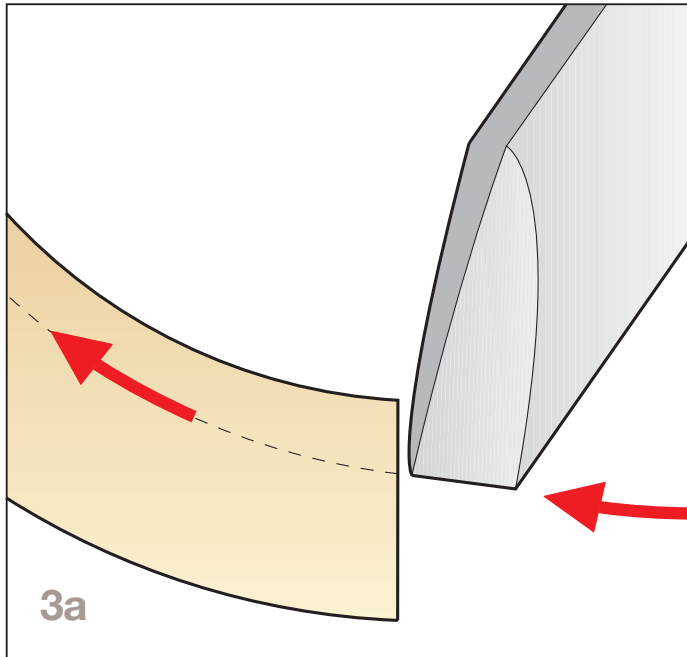

### SAFE

If your gouge is ground to the profile shown below, you get quick bevel support and reduce the chance for a catch. The red arrow indicates the cutting direction.

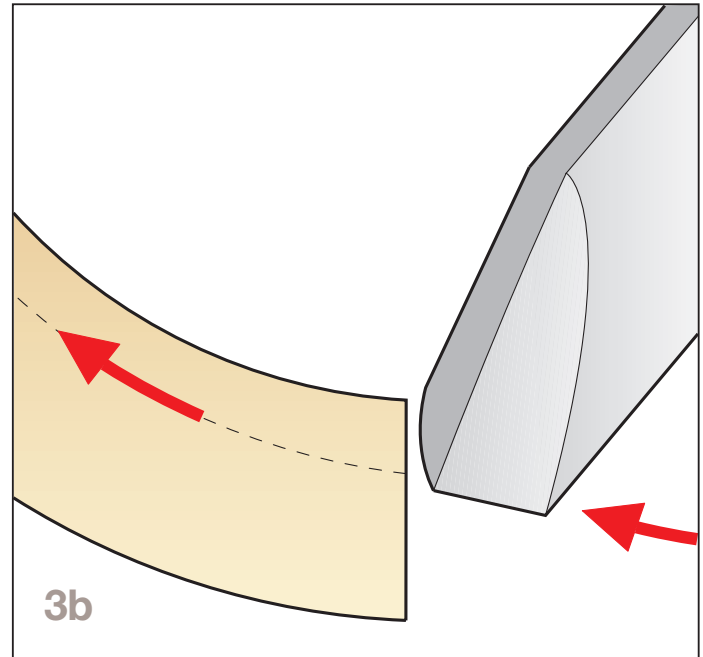

### RISKY

A gouge with a hump at the tip cuts into the wood long before the bevel has a chance to give support. This can cause a catch or even blow up a thin-walled bowl or vessel.

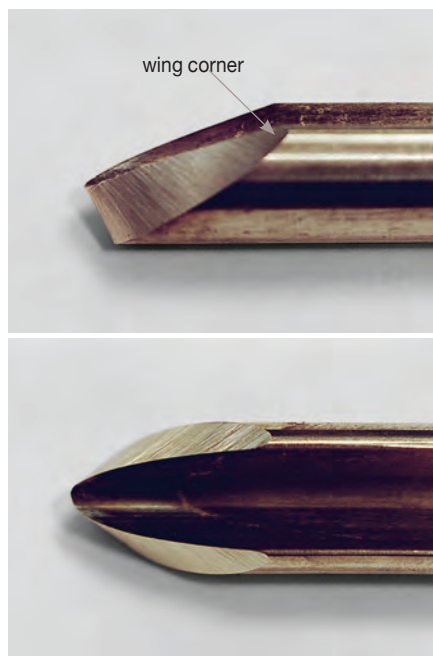

The wing (side) profile of Lyle Jamieson's favorite grind has a nearly straight line from the tip to the wing corner.

The bowl-gouge grind can make it easier to enter a cut. I reshape the Ellsworth grind slightly to make the entry into a cut easier for me, as shown in **Drawing 3a**. When I use a gouge with a slight hump near the tip, the tool attempts to grab the wood first before the bevel support has been established, as shown in **Drawing 3b**.

I prefer the sharpened edge that is almost straight from the top to the back corner of the wing—there is no hump when viewed from the side, as shown at left.

### Hollowing systems

When setting up your supported hollowing system for boring out the interior of a hollow vessel, make sure the scraper cutting tip is parallel to the floor and on the centerline of the vessel, and you will never get a catch. This setup will be cutting right at 90 degrees. (You can err slightly with

the tool-rest position on the high side, but never have the cutter below center in a hollow form.)

If you choose to twist the cutter for a shear cut, keep this in mind: When you angle one side of the cutter down to shear scrape, the opposite side of the cutter is pointing up into the wood and will get grabby and produce a catch.

### Scraper strategy

A scraper requires an entirely different process from a gouge. Whenever a cutting edge touches the wood without the bevel support, a catch can occur. (The exception is the edge touching the wood at less than a 90-degree angle, as shown in **Drawing 4a** and **4b**.) With a scraper positioned flat on the tool rest and parallel to the floor, the tool-rest height is critical. If the tool rest is high on the outside shape (like a spindle), it gets risky. If the tool rest

## Scraper positions for spindles and hollow forms

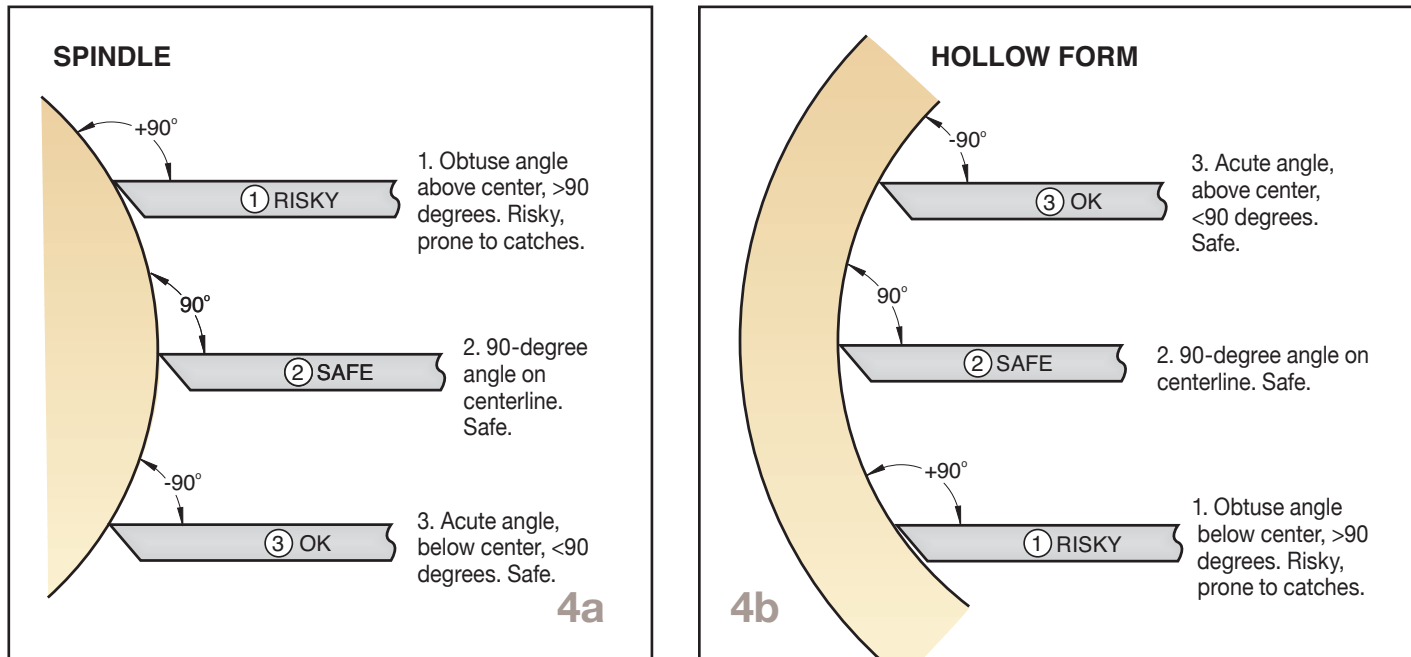

is too low on the inside shape, like a hollow form, it gets risky, as shown in **Drawing 4b**.

This is why negative-rake scrapers came into vogue. The negative rake gives you extra insurance to not violate the 90-degree rule. With handheld scrapers, you can change the angle at which the tool touches the wood by raising or lowering the handle.

### Move beyond fear

As I teach at chapters around the country, I meet many self-taught students. They settle for techniques that are difficult and demand considerable sanding, and some of the techniques are downright dangerous.

The fear generated from catches is suffocating. If you walk up to the lathe with catch butterflies, you are missing out on the true fun of woodturning. Do you worry about taking one more cut?

Woodturning enjoyment starts by being in control at the lathe. Taking “catch” out of your vocabulary will make turning a lot easier and more pleasurable.

You can watch others turn or read all the articles available and still have catch fear. I suggest getting some hands-on help. Take your turning job to the next level. It is not necessary to pay loads of money to get some woodturning instruction. All AAW chapters have good turners to mentor you—usually just for the asking.

Recently, I had a chance to speak with Michael Hosaluk, and he made a statement that summed up woodturning experience. He asked, “What is the difference between a beginner and an advanced turner?” And then he answered his own question with, “It is what you do with the basics.”

I truly believe in this approach. Get the foundations right, and it

opens up possibilities of excellence rather than creating obstacles and settling for mediocrity.

Now, let’s get over your fear of catches. The fun and creativity locked up inside you will take you places you never imagined.

---

*Lyle Jamieson (lylejameson.com) is a full-time woodturning sculptor and instructor who lives in Traverse City, Michigan.*

# Safety Lessons: Sharpening Jigs

Jim Rodgers

**A**s the use of sharpening jigs increases, so, too, do the instances of sharpening accidents. Injuries that result from fragmented grinding wheels and tools and holders that have slipped have sent woodturners to the hospital with serious injuries to hands and/or eyes.

Sharpening jigs were developed so that we could quickly and repeatedly produce a tool shape, bevel, and edge. When using these jigs, however, woodworkers need to be aware of some potential dangers. Tools can slide off the face of the grinding wheels and wedge between the wheel and the frame of the grinder; the arms of sharpening jigs can slip outward away from the wheel, causing the tip of the tool to move down the surface of the grinding wheel until the tool grabs at the wheel's

equator and instantly wedges itself, fracturing the wheel and potentially injuring the operator's hand; tools can slip forward in the tool holder itself causing similar problems.

While mechanical failure of sharpening jigs contributes to some injuries, human error is usually the cause. Here's why:

- The person sharpening the tool is distracted and the tool no longer rides on the wheel. A quick turn of a person's head can easily cause the movement of a tool off a 1"-wide grinding wheel, jamming it between the wheel and the body of the grinder.
- An improper handhold on the jig can cause fingers to be driven into the still-running grinding wheel.
- Too much pressure is applied to the tool causing mechanical slippage of the jig's arm.

- Improper grinding-jig geometry is set, placing the tip of the tool too close to the maximum diameter of the wheel (the equator).
- The process of sharpening tools is hurried.
- Small-diameter tools are improperly placed in jigs not meant to handle their smaller size.

## Proper use of grinding jigs

- Firmly lock the jig's extension arm and recheck it by pushing or pulling on it.
- Establish a more acute bevel angle on your turning tool. Placing the tool high on the sharpening wheel's surface reduces the possibility of an accident.
- Reduce the amount of downward pressure applied during sharpening; this will save tool steel and reduce heat buildup.



Using a simple shopmade template to set up your sharpening jig for repeatable distances saves time and tool wear.



Wrong way! If the sharpening jig slips, fingers will contact the rotating wheel before the jig does.

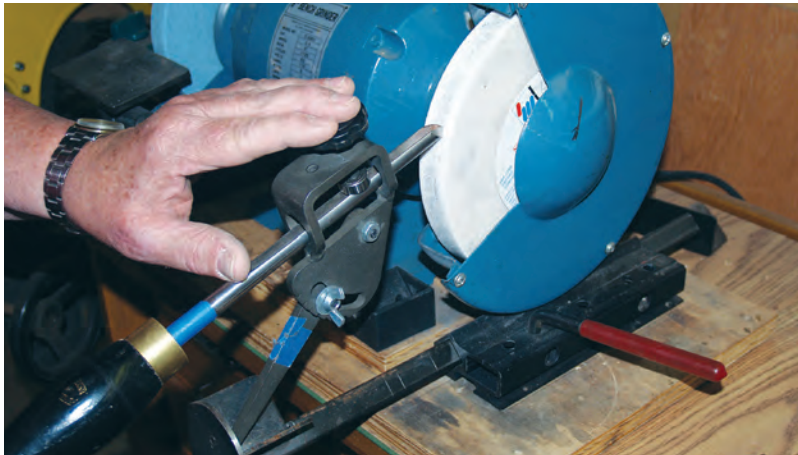

A safer way to hold the jig is on the top. If a slip occurs, the hand is protected.



Potential danger: Using a long fixture arm and a blunt sharpening angle brings the tip of the tool too close to the wheel's equator. If the arm of the jig slips or too much pressure is exerted, it could cause the tool to jam against the wheel.

### Wear safety gear

A faceshield or safety glasses should be worn while at the sharpening station. Eye injury is possible while sharpening as a result of flying debris. When dressing a wheel for cleaning or reshaping, wear a dust mask. The aluminum oxide dust from a grinding wheel is potentially damaging to lungs.

### Proper hold

When holding the sharpening jig, never place your hand between the jig and the grinding wheel. Place one hand on the handle of the tool and

the other on top of the jig. Accidents occur when the hand hits the rotating wheel during a slippage.

### Light touch

Sharpening should be done with a light touch; this reduces the amount of metal being removed and the heat buildup during the sharpening. A light touch also allows the operator to react quickly when a slippage occurs, perhaps saving a finger.

### New sharpening jigs

Until recently, most sharpening jigs managed the sharpening geometry well,

but still allowed for uncontrolled side movements that contributed to most accidents. Currently two manufactures, Sharp Fast and Oneway, have introduced jigs that eliminate the accidental sideways movement while maintaining the proper sharpening geometry. As a teacher of woodturning at both high school and adult levels, I would not be without such a jig!

*Jim Rodgers is past president of the Bay Area Woodturners and director of the turning programs for Mt. Diablo Unified School District. He can be contacted at [jlrogers@aol.com](mailto:jlrogers@aol.com) or [jlrogers.com](http://jlrogers.com).*



Better: Create a more acute bevel angle on your tool, which will place it higher up on the wheel in a safer position when sharpening.

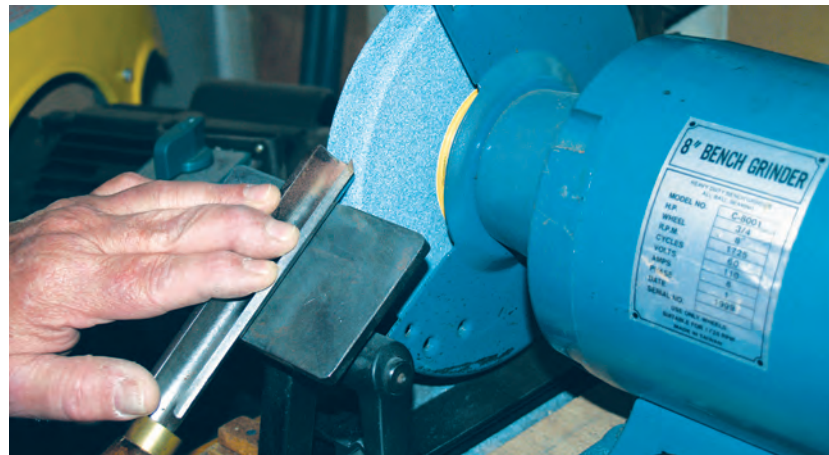

Consider learning how to hand sharpen turning tools. This allows you to place a toolrest close to the grinding wheel, eliminating many potential dangers.



# Safety Equipment: Wood Dust Solutions

John English

At the U.S. Department of Labor, somebody has a cheerful way with words. According to the Occupational Safety and Health Administration (OSHA), “wood dust becomes a potential health problem when wood particles from processes such as sanding and cutting become airborne. Breathing these particles may cause allergic respiratory symptoms, mucosal and non-allergic respiratory symptoms, and cancer.”

Of course there’s a lot of truth in what OSHA is saying. And while the government is primarily concerned with people who create dust as a byproduct of their jobs, every woodturner is exposed to some level of risk. Even among turners, those risks vary. As humans grow older, we are less able to combat the effects of environmental hazards. For example, our lung capacity decreases as the elasticity of our lungs declines. And it’s not just our lungs we should be concerned about.

According to OSHA, “exposure to excessive amounts [of wood dust] is considered to have an irritant effect on



eyes, nose, and throat, in addition to pulmonary function impairment, and is considered a human carcinogen.”

We should make responsible decisions, so let’s get informed.

## The nature of dust

Anybody who has perused *The Art of War* is familiar with the phrase “know your enemy.” Writing in the sixth century, Sun Tzu, a Chinese military strategist, held a philosophy that is still widely taught; it is as applicable in a basement workshop as it is in a combat zone. The smart way to fight, according to Tzu, is to learn as much as possible about the enemy in order to create an advantage for yourself. So, let’s do that by beginning with a discussion of the type of waste product that woodturners generate.

Turners create three distinct types of wood waste, and two of these are essentially innocuous. Large chips and gross dust particles are extremely difficult to inhale. While they may be hazardous as projectiles flying through the air, their collection and control is more a matter of workplace tidiness than a health issue. Fine dust particles, on the other hand, can be dangerous, and this is the enemy that we need to learn about.

There are two aspects to fine dust that determine risk. First is the size of the particles, and second is the concentration

Whether the dust collector has a fabric or a canister filter on top, it can usually be equipped with a clear plastic disposable collection bag below; this offers the distinct advantage of allowing the woodturner to see at a glance when the bag is getting full.



The most complete protection is offered by full-face visor/mask/shroud systems such as Triton’s powered ventilator, which was specifically designed for woodworkers.

of them in the air. Sawdust is generally in the area of less than 1 micron to 600 microns in size. A micron ( $\mu\text{m}$ ) is one-millionth of a meter ( $1/25,400$  of an inch) in diameter. To put that in perspective, particles smaller than 40 microns cannot be seen with the naked eye. Our lungs deal well with foreign bodies that are more than 7 microns in size. So, when a ray of sunlight reveals floating dust in the shop’s air, we’re only seeing particles that are five or six times larger than the ones that can hurt us. Those invisible enemies are so small that our natural respiratory filters can’t catch them.

But size isn’t everything. The number and concentration of particles in the air is the real key. Jobsite exposure to wood dust causes significant increases in respiratory problems at exposure levels as low as  $2 \text{ mg/m}^3$  (just 2 milligrams per cubic meter). The National Institute for Occupational Safety and Health (NIOSH) recommends exposure limits that are half that:  $1 \text{ mg/m}^3$ . So, here’s a sobering thought: Sanding a bowl with fine grit paper produces a concentration several hundred times the NIOSH level

Many smaller dust collectors now offer canister filters rather than fabric ones. The filters replace the top fabric bag and any buildup of powdered dust can be removed by simply turning a lever (on top), instead of trying to beat the dust from the inside of a bag.



in the immediate vicinity of the work.

It is not just the cellulose debris that needs to be addressed. Adverse health effects also come from biological organisms such as mold and fungi that grow on or in the turning blank. Scraping and sanding wood while it is on the lathe will release these particles, and will also free the residue from adhesives used in segmented or repaired work. Furthermore, concentrations of wood dust may create a mixture with air that can explode and will also burn readily if ignited by a spark or flame.

The government has come up with a lovely acronym for this weighty topic: LEV (local exhaust ventilation). LEV describes the three main dust solutions available to turners: powered masks and helmets, ambient filters (those large, ceiling-hung boxes that scrub the shop's air), and dust collectors/shop vacuums equipped with filters to handle fine particles. The latter is the most effective and perhaps the least understood of the three, so let's begin there.

### Dust collectors and shop vacuums

Dust collectors are all about volume, while shop vacuums are into speed. Dust collectors pull large amounts of air through their filters,

Oneida has created an aftermarket add-on cyclone that can be attached to a single-stage dust collector, in effect transforming it into a two-stage unit that separates the dust from the chips. A two-stage filter keeps filters cleaner and more efficient, and is easier on impeller fan blades.



while shop vacuums have more suction but move far fewer cubic feet per minute (cfm). Power in both types of machine is measured in terms of static pressure, which is the ability to pull up water in a controlled test. A dust collector can raise a column of water about a foot up a tube, while a shop vacuum can pull the same column perhaps five times as high.

However, the average woodshop dust collector has a 4" or 6" (10cm or 15cm) inlet and it will move between 650 and 2,000 cfm, while a shop vacuum hose is only 2½" (64mm) in diameter and can pull less than 200 cfm (and about a quarter of that with a smaller, 1¼" [32mm]-diameter hose). A typical one-car garage workshop contains about 2,000 cubic feet of air. A larger dust collector can filter that much air about once

a minute, while an average shop vacuum handles less than 1/10 of that volume in the same amount of time. And because of its low volume, the shop vacuum will primarily recycle air close to it, rather than scrubbing air from remote corners of the room.

A lathe generates dust about halfway between the floor and the ceiling in most shops, so the

contaminants are well distributed through the workshop and especially around our mouths and noses. During turning, sandpaper is static while the work revolves, and that motion tends to spread the dust around. Because of its small hose and lack of volume, a shop vacuum is fairly ineffective at collecting fine particles around a lathe, no



Collectors equipped with two pairs of bags are designed to share a single, larger motor. The airflow is split, allowing twice the room for waste in the lower bags and twice the amount of fabric filter in the upper ones.

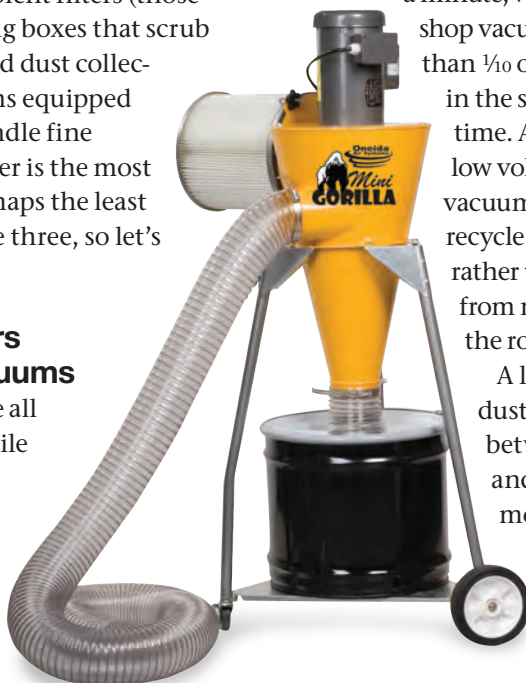

Starting at just 1 HP, the Mini-Gorilla dust collector from Oneida is ideally suited to space-challenged shops, where a turner needs high efficiency, a cyclone separator, and 600 cfm of airflow to collect the fine and coarse waste from a single lathe.



Combining the benefits of cyclone separation with an exterior two-stage filter and a large debris bucket, the 2 HP Super Gorilla from Oneida is a unit well suited to turners who take on larger bowl projects, and therefore need more than one dust port.



Oneida Air System's portable collector is designed for woodworkers and turners who don't have a central dust collection system with lots of ductwork already in place. The cyclones create a vortex that uses centrifugal force to separate dust from chips.

matter what kind of dust port is used on the end of the hose. It'll get the big bits, but the harmful ones can enter our lungs.

On the other hand, dust collectors usually force the air back into the room through a large fabric bag rather than through a small cylindrical filter. The weave on the bag determines what size particles are returned to the room. Bags are available aftermarket for most collectors, and many handle dust down to one micron or less. There is a point of diminishing returns, where the filter openings are so small that they restrict the airflow to the point that the dust collector loses much of its volume. For most machines, that watershed is in the neighborhood of one to two microns, while some manufacturers recommend staying above four microns, just to maintain airflow. Some of the high-end shop vacuums now come with cartridge filters that will scrub the air down to a very respectable level. These high efficiency particulate air (HEPA) filters are required to remove at least 99.97% of airborne particles 0.3 microns in diameter. However, they simply can't handle high volume, and that's what turners need to address their dust.

Storage is important, too. A shop vacuum's waste tank is generally in the 5 to 10 (20 to 40L) gallon range, while a dust collector bag doesn't need to be emptied until it has accumulated several times that. Many are even set up for 30- or 55 (110- or 210L)-gallon drums. That encourages people to use the machines. Nobody wants to stop working every few minutes just to empty a dust bag.

There's one more health concern with shop vacuums: most models are very noisy. However, there are mufflers made for most shop vacuums, including a fairly universal one from Sears.

The bottom line is that dust collectors serve turners better than shop vacuums, primarily because of the sheer volume of waste that we generate and the number of air exchanges we require to protect ourselves.

### Selecting a dust collector

The critical numbers to look for in a dust collector are volume and static pressure. Volume is described in cubic feet per minute (cfm). While the horsepower rating gives some indication of a unit's abilities, different manufacturers measure horsepower in different ways and that often leaves the woodturner comparing apples to oranges. But the volume of air that a fan can move is a fairly reliable number.

If the lathe is the only tool hooked up to a dust collector, or all the other machines can be isolated with blast gates so that only the lathe is being served, a collector with volume in the 600 to 1200 cfm range is quite adequate for most work, if it isn't located too far away. Turners with large bowl lathes who are turning vessels that exceed 16" (41cm) or so in diameter will need more volume.

The second half of the equation, static pressure (SP), can be confusing. For example, Grizzly offers an excellent two-horsepower cyclone dust collector (model G0440) that pulls 1,354 cfm at 2.5" (6cm) SP. That is, it moves 1,354 cubic feet of air per minute at 2.5" (6cm) of static pressure (the amount of suction required to raise a

column of water that high). However, the specs on this machine



The Dust Deputy from Oneida turns an ordinary shop vacuum into a two-stage unit, where the larger particles are sent to the bucket and the fines are trapped and collected in the unit's standard bin.



Filtering up to 1,400 cfm, the G9956 from Grizzly can scrub all the air in a two-stall garage shop in an impressively scant three minutes, providing twenty changes an hour. It runs on a 1/3 HP, 110-Volt motor with remote and three speeds.



Weighing just 18 lb (8kg), this freestanding version of a ceiling-mounted whole-shop filter is offered by Shop Fox. It filters down to an impressive 0.3 microns, and because it is unattached, it can be placed close to the lathe, especially during sanding tasks.

Ceiling-hung shop air filters such as Grizzly's G0572 usually have a remote control for the three-speed motor, an automatic timer, and two filters (in this case a 5- and 1-micron). The 1/5 HP motor runs on standard 110 Volts.

also note that the maximum SP is 10.4" (26cm). In other words, the machine will not move air at a higher suction level. The key here is that, as the static pressure rises, the volume of air falls. So, when comparing two dust collectors, one needs to compare their volumes (cfm) at the same SP. If a salesperson is touting an impressively high volume of airflow, the odds are that he or she is not mentioning a very low suction rating.

Beware of a SP number that is quoted without cfm. If a machine is rated at, say 16" (41cm) SP, it's a safe bet that this is the maximum SP it can generate, and at that pressure there is absolutely no airflow. The bottom line is that a good two-horsepower dust collector should be able to draw about 1,500 cfm at 12" to 14" (30cm to 36cm) maximum SP; a three-horsepower unit should handle 2,000 cfm; and a four-horsepower machine should be in the 3,500 cfm range.

Aside from airflow, some other design aspects are worth noting. Two-bag collectors have a filter bag on top and a collection bag on the bottom. Four-bag units simply double the filter and collection areas. Clear poly bottom bags (as opposed to canvas ones) really help, as they make it immediately obvious when the collector needs to be emptied.

Machines with canister filters have a pleated filter instead of a fabric bag, and the big advantage here is that, when dust cakes on the inside, it's just a matter of

moving a handle to knock it loose and regain full airflow. The canister filter is usually made of polyester, and many filter down to less than 1 micron. The pleats allow for a larger filtering surface in a smaller physical area.

A cyclone dust collector has a large funnel-shaped plenum that forces the incoming air to swirl in a circle, so that large and small particles are separated by centrifugal force. In general, there is a canister for large chunks and a bag for fine particles. For turners, there isn't a whole lot of advantage, considering the extra expense, as we generally don't create large waste on the lathe. A more budget-sensitive solution is to create a two-stage collector by adding a garbage can and a special lid to a single-stage unit (the lids are available at [nosawdust.com/cyclone\\_lid.htm](http://nosawdust.com/cyclone_lid.htm)).

### Ambient filters

These are also known as air scrubbers or whole-shop filters. They most often take the form of rectangular, ceiling-hung metal boxes with a fairly powerful fan that is located behind one, two, or even three stacked filters. The salient factors to consider when choosing one of these air filtration systems are the same as those used to decide on a dust collector: how much air does it move, and how efficient are the filters? The higher the volume (cfm) on the outfeed side

Several manufacturers now offer custom and aftermarket high efficiency filters for shop vacuums and most of them are capable of trapping more than 99% of the small particles that cause pulmonary problems.

of the unit, the quicker it will scrub the air in your shop. Try to find a unit that will recycle the cubic feet in your space (length × width × height in feet) at least every ten minutes.

Most of the newer units come with a remote control, which is handy for people who are less than 7' (213cm) tall. They usually have three speeds (in the neighborhood of 400, 600, and 800 cfm), and will cycle the air in a two-car garage between five and ten times an hour. There are generally two filters, a coarse one that collects dust in the 5-micron plus range, and a fine one that works all the way down to 1 micron or less. Better models come

A freestanding dust port that has its own independent, adjustable stand and a wide funnel-shaped mouth is ideal for collecting dust on the lathe. These units can be placed so close that they almost touch the work, and angled upward a little to catch falling chips.





The 11121 Lathe Dust Hood from Big Horn Corporation has a hinged, clear viewing shield that swings completely out of the way. It comes with universal mounting brackets for a custom fit on many different brands of lathes, and it works with a 4" (10cm) hose.

### Pressurized dust masks

In addition to running a collector, a great many turners now wear a pressurized mask system (also called a powered respirator) while sanding or doing other tasks that produce dust or vapors. These units can seem a bit pricy, but they work very well. There are two types: a small breathing mask that pumps air out faster than the operator can breathe it in, and a full-face unit that incorporates a Plexiglas face screen, and sometimes a helmet, too. The latter provides face protection from impacts, and allows the user to wear eyeglasses without fogging. Beards can be a problem with conventional dust masks, but they're not an issue with most powered respirators.

Perhaps the most popular respirator is one made by the Australian company, Triton. This is more of a system than just a mask: it has a helmet designed to guard the head from impact, a faceshield to save eyes from flying debris, and a shroud and filter to protect lungs from fine dust. The shroud is a soft plastic fabric that rests on the shoulders, sealing the bottom of the system.

The key component in Triton's respirator is an air filter that sucks in air through a belt-mounted, battery-operated filter that hangs on the user's waist. The batteries are rechargeable. The filter usually contains two or three separate filters that meet US N95 NIOSH standards (P2 in Australia). They eliminate up to 99% of the dust particles that are under one micron in diameter, and 95% of particles down to 1/3 of a micron in size. At around \$210, Triton's system delivers 4.23 cfm without any accessories. For more information, visit [tritontools.com](http://tritontools.com).

with timer settings (they can be run for several hours and then they shut down automatically), and the motors are almost always 110 V that generates less than 1 HP, so they can be plugged into a standard ceiling or wall outlet. (Make sure the ceiling outlet isn't designed for lighting, and is controlled by a switch.)

Depending on the thickness of the sheet metal housing and the size of the motor, ambient ceiling-hung filtration systems weigh between 40 lb and 80 lb (18kg and 36kg), so they need to be anchored soundly to the underside of floor joists or trusses.

For some very impressive guidelines on building an inexpensive, shopmade ambient filter and downdraft sanding table combo, visit [woodworkersworkshop.com/plansshare/air\\_filter\\_downdraft\\_sanding\\_table.htm](http://woodworkersworkshop.com/plansshare/air_filter_downdraft_sanding_table.htm).

Lightweight face and lung protection is provided by three sizes of battery-powered ventilators offered by the 3M Company, the 6700, 6800 and 6900PF masks.



Smaller versions of the powered respirator are available. One of the more popular ones is made by the U.S.-based 3M Company (3M.com). The company refers to its model 6800PF mask as a Powered Air Purifying Respirator. It uses a single filter and delivers four cfm of clean air. The system includes a faceshield, motor blower unit, belt, battery pack, flow meter, and high efficiency filter. A small version (6700PF) and a large one (6900PF) are available. Typical prices run about \$400.

Wearing a powered respirator feels a bit strange at first, but it doesn't take long to get used to it. Most are quite lightweight and ergonomic. There's a small rush of claustrophobia the first time it's worn, but once the air starts moving and the face shield stays clear of fog, it actually feels reassuring. One wouldn't wear it to the grocery store, but in the private confines of a workshop, this strange garb is literally a lifesaver and can extend the joyful years of turning. It can help avert the onset of numerous pulmonary problems, and can also help make turning possible for folks with asthma, mild emphysema, various allergies, and susceptibility to dust-related illnesses.

### Dust masks: A word of caution

One of the great misconceptions of dust control is that inexpensive white fabric or paper nuisance masks offer some protection while turning. It's worth noting that reputable companies such as 3M place a warning label on their version of these, and it literally reads: "*This mask will not protect your lungs.*" (Less scrupulous manufacturers print the label

Inexpensive nuisance masks offer virtually no protection whatsoever against fine sanding dust, and lull some turners into feeling so safe they don't use a dust collector.





The Dust Bee Gone reusable dust mask is available in several sizes.

in small print on the package rather than the mask, or not at all.) Nuisance masks not only allow almost all of the dangerous small particles through, they also impart a false sense of security. People using them for wood dust filtration feel as though they are doing something to protect themselves (which, of course, is completely false), so they don't bother taking any other real steps such as installing an

air scrubber, hooking up to a dust collector, or investing in a powered respirator.

Beyond the cheap, disposable versions, there are some nuisance masks such as the Dust Bee Gone that, although not NIOSH or OSHA approved, still filter down to 3 microns. The mask accommodates to most faces, even those with beards, has two straps to help close gaps around the edges, won't fog up glasses, and is actually made in America. For more information, visit [dustbeegone.com/dustmask.html](http://dustbeegone.com/dustmask.html).

After all is said and done, woodturners who take precautions against inhaling wood dust will be able to enjoy their time at the lathe without fearing respiratory health hazards. The consequences of exposure are just too risky to take casually.

Many additional fact sheets and articles on the hazards of wood dust exposure can be found online at a number of websites, among them:

Ohio State University Extension Service [ohioline.osu.edu/aex-fact/0595\\_1.html](http://ohioline.osu.edu/aex-fact/0595_1.html)

State Compensation Insurance Fund [scif.com/safety/safetymeeting/Article.asp?ArticleID=125](http://scif.com/safety/safetymeeting/Article.asp?ArticleID=125)

WoodBin Woodworking [woodbin.com/misc/wood\\_dust\\_toxicity.htm](http://woodbin.com/misc/wood_dust_toxicity.htm)

Health and Safety Executive [hse.gov.uk/pubns/wis1.pdf](http://hse.gov.uk/pubns/wis1.pdf)

*John English is the author of The Woodworker's Guide to Sharpening and How to Choose and Use Bench Planes. He teaches furniture building and cabinetmaking at the Black Hills School of Woodworking.*

## Dust control Malcolm Zander

In a past issue of *AW*, I described the use of a polyethylene sheet tent around the lathe to isolate the dust and shavings from my workshop. This enclosure keeps the workshop clean, but I still have to stand inside the tent and breathe sanding dust—even with the best dust extractor system.

To help remedy this problem, I bought a Triton powered respirator helmet (upgraded from a now-defunct Racal helmet), but found that the daily cleaning and replacement of the inlet air filters was a major hassle. So I eliminated the belt-mounted battery pack/fan/filter and replaced it with clean air ducted in from another room in the house.

Clean house air arrives through a 5" (125mm) duct that is connected to a 200 cfm bathroom-type blower in

another room of the house. A furnace filter is placed over the fan intake.

By using standard plumbing hardware, the ducting diameter is reduced to 1½" (30mm) to fit the Triton hose. The central vacuum hose extension allows me to reach anything within a 10' (3m) radius of the lathe with good ease of movement.



The duct run is 20' (6.5m) long. To give the proper airflow rate required inside the respirator, a 200 cfm (5.7m<sup>3</sup>/min) blower with a squirrel-cage centrifugal fan (as opposed to an axial fan) was needed to overcome the resistance of the ducting and the smaller diameter hose restriction.

This system blows clean room-temperature air directly into my helmet. When sanding, I am unaffected by the dust cloud inside the tent. The respirator is comfortable and very quiet, and I wear it virtually all the time when turning. One additional advantage to this setup is that when my wife is baking muffins in the kitchen I can tell within seconds.

In order to see the duct setup, I have removed the plastic tent around the lathe.

# Safety Equipment: Collect Dust at the Lathe

The Editors

---

**P**eter Fedrighon knows dust. For more than 20 years, he's hopscotched across the country as a consulting engineer on dust collection, air filtration, and system design.

For the 650 employees at the L. & J. G. Stickley factory, he designed a monster system with three 150-hp fans that suck wood dust from the plant and blow it into a towering filter dubbed the "baghouse."

*"I turned for four or five years and only occasionally wore a mask. Now, I have asthma from breathing wood dust. Bad situation—I pay for three days if I get even a puff of sawdust in the nose. I recommend moving as much air as you can when you sand. Take good care of your lungs!"*

---

—David Ramsey, Phoenix-area segmented turner and retired hospital executive

He watches over 40-plus systems. At a Wrigley Brothers plant in Gainesville, Georgia, the system protects the lungs of 850 employees from sugar dust.

Variety? Peter has designed systems for rock crushers, tobacco, clay, and peanut shells. And of course, plenty of wood dust.

In the mid-1990s, he started Oneida Air, which his daughter and son-in-law now run.

In sprawling factories, there are rigid OSHA standards for dust levels, which could get out of compliance from poor dust collection and improperly maintained return air from bag-room filters.

Of course there are EPA standards for the air vented outdoors. And the explosive dust must meet National Fire Protection Act requirements.

"All the factors that apply to industry also apply to our home shops," Peter says. "Think about this: The EPA doesn't allow dust masks in factories—the dust collectors have to do all the work. That's the way it should be in your shop, too."

Peter can quote dust statistics until your eyeballs roll into the next ZIP code. But his bottom line message is simple: "If you like to turn, you'd better get yourself a dust collector."

Peter is just as strident about the importance of dust collection for the AAW turners as he is about his consulting jobs. When he's home, Peter relaxes at his lathe.

Members of the Central New York Woodturners are fortunate to have him as an active member. Peter estimates that he's set up or upgraded dust systems for more than 50 members. And of course, he's always eager to talk about his favorite topic—dust.

## Microns and your lungs

If you're considering adding a dust collector to your shop (and you should), you could easily get lost in a sea of technical jargon. You'll find more explanations in the sidebar "Dust Terminology."

Most of the advertising material speaks about the ability to gather dust whose particle size is measured as micrometers, or microns.

Here's what you need to know about microns:

- There are 25,400 microns in an inch. The period at the end of this sentence is about 320 microns in diameter.
- It is the tiny particles which you breathe in that damage your lungs. The dust from 1 to 10 microns in diameter is the nasty stuff that is harmful to lung cells and causes respiratory problems—coughing, nosebleeds, sinus problems, emphysema, and bronchitis. That may explain why you develop a cold after you spend a lot of time sanding. The finer you sand, the finer the dust particles.

By comparison, wisps of tobacco smoke fit in the range of 0.01 to

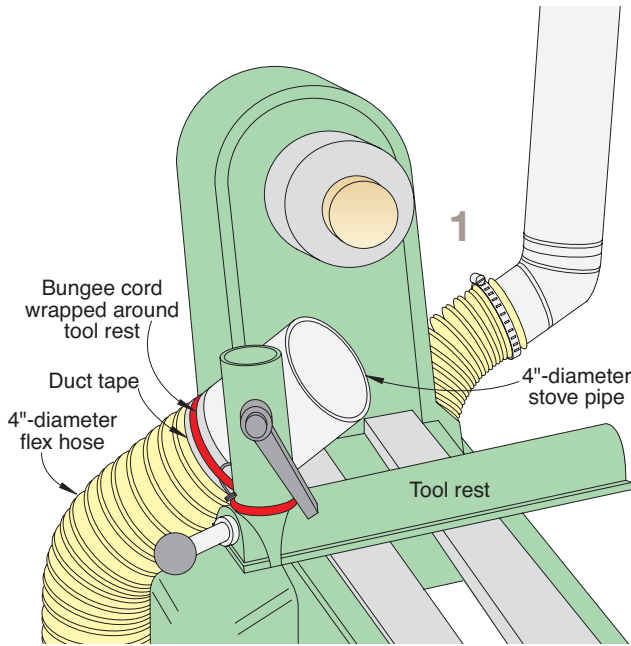

## Get after dust!

*Left:* A method to gather dust while turning.

*Right:* When sanding, add a second 4-inch diameter hose fitted with a hood.

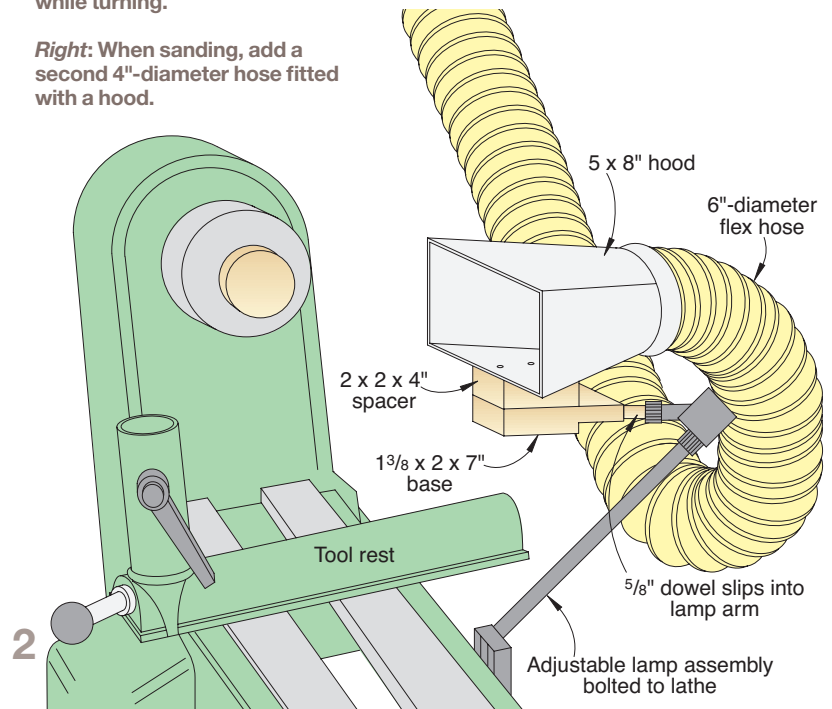

1.0 microns. Of course, you know what damage tobacco smoke does to healthy lungs.

In your shop, you can sweep up the nuisance chips too big to enter your lungs. It's the tiny particles and sanding dust that should be your biggest concern.

### Collect dust at the source

Peter has a simple solution for gathering chips, shavings, and dust when he turns: He attaches a 4-inch diameter flexible duct to his tool rest with a bungee cord, as shown in **Drawing 1**. "I don't even start up my lathe without turning on the dust collector," Peter says. "This duct is never in the way while I turn. The thin flex hose lets me move the tool rest around with ease."

When it's time to sand, Peter opens a blast gate to a second 4-inch diameter duct fitted with a hood, as shown in **Drawing 2**. With two ducts running, he gets 600 to 800 cfm through his 2-hp cyclone system.

"I keep the hood opening small so the air can reach out to capture the dust. I'm getting about 99.9 percent of the dust collected right at the source.

"Remember that dust is a fire and explosion hazard, too." The dust-gathering solutions *above* are typical of what he has set up for the home shops of Central New York chapter members and nearby AAW chapters (word of Peter's knowledge spreads faster than dust).

### The filter factor

"Dust filtration is critical," Peter says. "If you can see dust migrate through the bags when you turn on your collector, your system needs immediate attention.

"It is important to understand the filter media and the efficiency of the media. Spun-bond polyester filter media in pleated filters is the best for your shop.

"The woven or felted polyester doesn't do as good a job because it

can't hold back the high dust-loading that occurs in home shops. In addition, woven filters must be cleaned often."

When you choose filters, Peter suggests you select wide-pleated cartridges. Today's top-performing cartridges can filter 99.9 percent of the dust down to .02 micron.

### A better two-bag collector

Peter has helped several chapter members upgrade a two-bag collector. Among his solutions:

- Replace the 30-micron bag (standard with many collectors) with a more efficient 1- or 5-micron bag. (The replacement bag will be larger.) American Fabric Filter ([americanfabricfilter.com](http://americanfabricfilter.com), 800-367-3591) provides technical support for aftermarket bags.



- Replace the top bag with a pleated canister filter, which provides at least four times the media surface over a cloth bag. For details, check with your original manufacturer. Donaldson Company (airfilterusa.com, 800-667-8563) is one online source.

### A system for your shop

There's not one perfect system for every shop, but Peter's design looks something like **Drawing 4**.

Whatever choice you make for a dust collector, Peter urges you to keep it running in top form. To check his shop system's efficiency, he spent less than \$5 in a U-tube manometer assembled from plastic and copper tubing and colored water. This device, shown in **Drawing 3**, measures the static pressure required to push air through the filter.

On his system, Peter knows that if the pressure jumps by +1.5", it's time to clean his filter. For best results, Peter recommends that you install the manometer between the fan and the filter, as shown in **Drawing 4**. "You can even install this on your two-bag system. Poke a hole in the flex hose right before the bags. You'll see an amazing improvement if you monitor this."

You also can buy an 8" flex U-tube manometer for about \$20 (dwyer-inst.com).

### Understand fan curves

Okay, this is getting a little technical. But your lungs will love you if you just stick with this.

If you've gone to the trouble of checking your systems and efficiency, you'd better at least have a pedestrian knowledge of a fan curve. When adding a manometer to check on your system, the fan curve, as shown in **Drawing 5**, takes on new meaning.

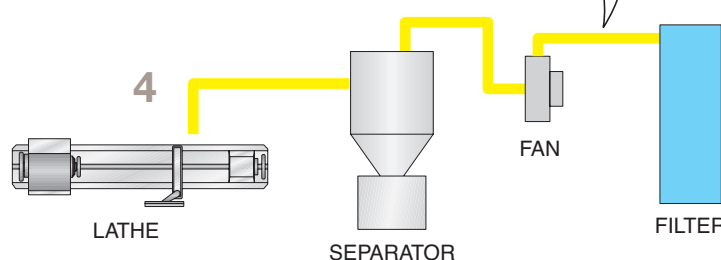
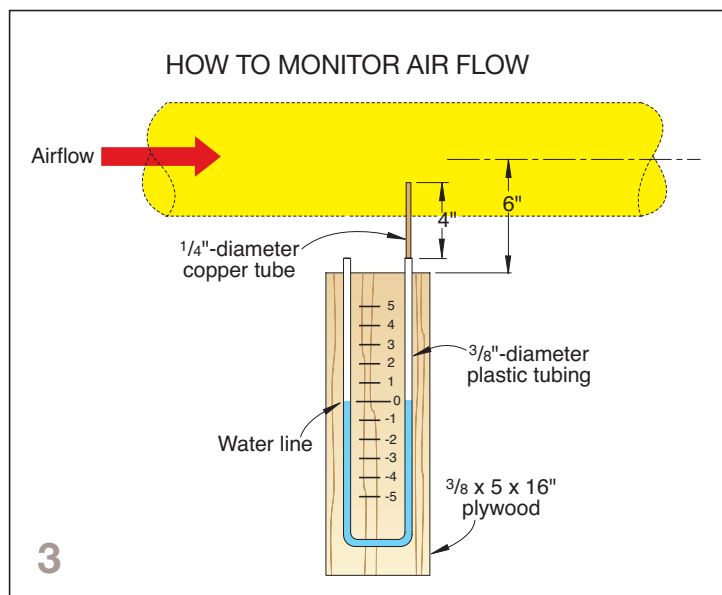

In Peter's shop, he knows that with 8" SP (static pressure), he's getting about 880 cfm in his shop. See how an additional 1" of static pressure (resistance from clogged filters) drops his system from 880 cfm (blue line) to down to 600 cfm (red line). Result: much less suction to grab up all that sanding dust.

You may have noticed that your shop-vacuum barrel doesn't have to be full to lose its efficiency. The same story is being repeated in shops all across the country.

Be sure you know the true capacity of the system you're considering installing. Some companies advertise a fan of 1,200 cfm or greater. Sounds impressive, right? But add your duct work, as **Drawing 5** shows, and the cfm drops dramatically.

### Separate grinder system

Don't forget to connect your grinder to a separate dust collection system. Because grinding involves sparks, you don't want this machine to share the same lines as your wood dust system.

Peter recommends a shop vacuum (at least 70 cfm) connected to your grinder dust port, as shown in **Drawing 6**.

"You can easily set up your collector so it automatically turns on every time you switch on the grinder," Peter advises. "It's real easy to switch the hose from one side of the grinder to the other."

"Aluminum oxide and ceramic dust from grinder wheels are really nasty stuff. You're especially throwing off a lot of dust when you dress your grinding wheel."

5

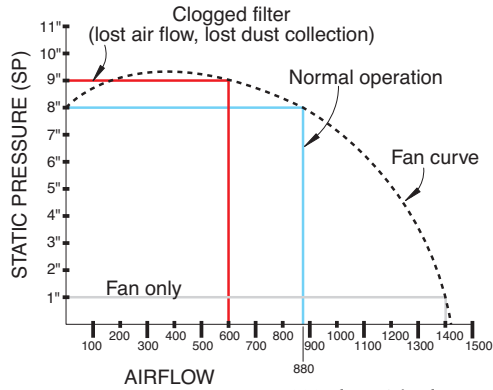

Filter clogged (more resistance, higher static pressure)= 600 cfm

If you're not a dust engineer, you could easily get sucked up in a dust storm of numbers and acronyms. Here are some key definitions:

**Air Volume.** The amount of air that is moved through the duct in a prescribed amount of time. Air volume is measured in cubic feet per minute, expressed as cfm. A roll-around shop vacuum may have a rating of 70 cfm; a complete system for a home shop (with blast gates, hoods, and ductwork) should be in the range of 600 to 800 cfm.

**Static Pressure (SP).** Moving air through a pipe, cyclone, or filter involves resistance. Stick your hand out of the car window and drive down the road at 5 mph—that's static pressure you feel. When the resistance from each of your machines is added together, the total is the amount of static pressure the fan needs to produce.

The above are all the things created by the fan and these are the necessary requirements your fan should overcome to perform as a reliable dust collection system.

**Want to learn more?**

Here's a website you can learn more about dust collection: [allwoodwork.com/article/woodwork/gettingtoughondust.htm](http://allwoodwork.com/article/woodwork/gettingtoughondust.htm)

**Dust terminology**

Okay. You've decided to make the investment in your respiratory system by reducing your sawdust. Now what?

Your dust collector fan creates the criteria that follow. If your fan can meet these requirements and collect dust, you have a good system.

6

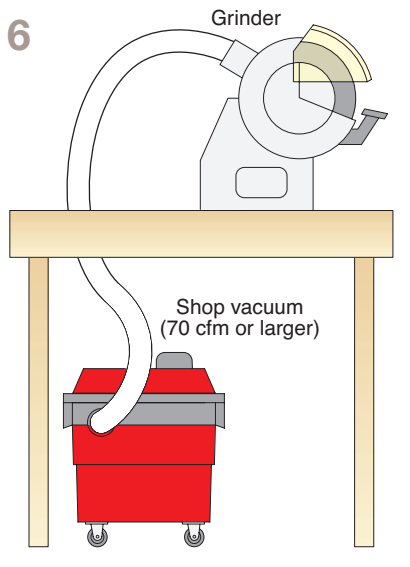

A simple dust collection system at your grinder will trap aluminum oxide and other harmful dust from your wheels.

Illustrations: Roxanne LeMoine

**Control noise**

Woodturners who do battle with dust wrestle another nemesis: irritating noise from the collector. The noise comes from the exhaust side of the fan; the higher the velocity, the greater the noise.

Many dust collectors now include a silencer or have silencer accessories (something like a muffler on an auto).

The turners who use "too much noise" as a weak reason to avoid installing or running a dust collector, you need a better plan.

One strategy is to locate the collector beyond the shop (either outside or in an adjoining room). Morton Kasdan, a member of the Louisville Woodworkers Association, chose to locate his 3-hp cyclone collector in the center of his shop, which reduced the length of his duct runs.

Mortie dampened the noise in his shop, a converted three-car garage, by constructing a 3x2' closet framed by 2x4s and covered with 3/4"-thick plywood. (The top sections surrounding the external



filters are larger.) Each side is lined with insulation panels, as shown at left. A hinged door makes it easy to empty the dust barrel; he can easily

remove four clamps on one side for filter maintenance.

Mortie also added an insulated top over the closet that has 4"- to 6"-wide slots for air exchange. Perforated hardboard over the plywood panels expands his tool hanging storage.

Although the center location in his shop reduced the length of duct lines, Mortie lamented that "If I had it to do over, I would put the collector in the corner. I could control the noise better there. Regardless, the insulation has reduced the noise level significantly."

# Bandsaw: Safe Setup and Operations

Keith Tompkins

There is potential danger lurking in the corner of woodturning shops, waiting for the most inopportune time to injure or maim. For some, the thought of operating a bandsaw strikes fear; we have all heard horror stories of bandsaw accidents. The bandsaw's negative reputation, however, is largely undeserved. If we follow a few guidelines, the bandsaw can be one of the safest, and most versatile, of all stationary woodworking equipment. Let's see if we can demystify this machine and acquire a comprehensive understanding of how to operate it safely.

## Know your machine

Before operating any power equipment, it is imperative to have a basic understanding of its functions, adjustments, and maintenance and safety procedures. Read and periodically review the owner's manual; it contains necessary information required to properly set up and maintain your bandsaw. If you have mis-

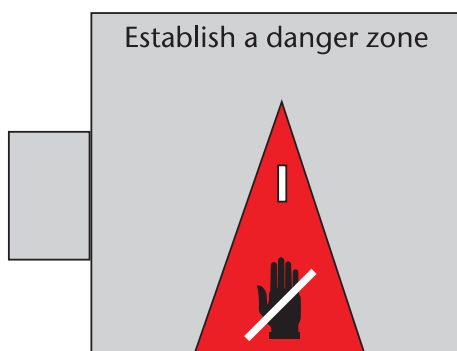

Figure 1. The red triangle illustrates the danger zone area: the area where it is not safe to place hands and fingers when making cuts on the bandsaw.

placed your owner's manual, many manufacturers make copies available online. Excellent books and articles on setting up and operating bandsaws are also available (two books are listed at the end of this article). If you are unsure of any bandsaw function, most turning clubs have experienced operators who will be willing to give proper instructions. Under no circumstance should you operate a piece of power equipment without proper training, when tired or under the influence of alcohol or medications, or when the equipment is not in good working condition.

## Safety

While there have been many publications written about the bandsaw, very little information on bandsaw safety, as it applies to woodturners, is available. This article will focus on safe bandsaw operation and will cover the basic cuts employed by woodturners.

Before using any power woodworking equipment, ensure a clean work area free of obstructions. Remove rings, watches, and other jewelry. Avoid wearing loose-fitting clothing or shirts with long baggy sleeves, and if you have long hair, securely tie it back. Always wear eye protection (a faceshield is best). Even when every precaution is taken, you may find yourself in a dangerous situation. Be sure the on/off switch is located in a convenient, easy-to-reach location.

Establish and adhere to the concept of a danger zone (Figure 1). This zone is an area where an

operator's hands are not safely placed when cutting wood. The red area indicates the danger zone, as seen from above the saw's table. Keeping your hands out of the danger zone will significantly reduce chances of injury while operating the bandsaw. As obvious as this may seem, nearly all bandsaw accidents occurred because the operator placed his hand directly in the path of the blade (in direct line of the cut).

Good posture and body position are important; you may inadvertently place your hands in danger if you lose your balance. Stand with a relaxed posture, feet balancing your body so that you are squared up in front of the table. Avoid reaching too far forward or to the sides. I recommend an open stance while cutting large pieces. This gives you the ability to react in any direction. Avoid standing flat-footed. Imagine you are resisting someone pushing: feet together, no resistance and easy to push over. Open stance, good resistance and balance.

## Condition of the bandsaw

Cutting bowl blanks safely begins *before* the bandsaw is turned on. The condition of the saw blade is of utmost importance; many accidents are the result of the operator attempting to cut with a dull blade. Never operate a bandsaw with a dull blade. Resist the temptation to take just one more cut when you *know* the blade needs replacing. For every action, there is an equal and opposite reaction: If you are

pushing hard, trying to make a cut with a dull blade, as the blade exits the wood, the bowl blank will jump forward, possibly pulling your hand directly into the path of the blade. The blade may be dull, but it will still cut off a finger.

When installing a new blade, disconnect the saw from the power source, then adjust the tension, blade guides, and rollers to the bandsaw's and blade's specifications. At the same time, inspect your saw and make necessary adjustments or replace worn parts. The following are things to check before and during installation:

- Check the condition of the rubber tires on each wheel. Obvious cracks, chunks of missing material, or a loose rubber tire indicate replacement is required. If the tires are in good condition, clean each tire using a thin piece of scrap wood or stiff nylon brush.
- Thrust bearings play a role in proper bandsaw setup and use. The thrust bearings are located behind the blade (one above and one below the table), and they should move freely so that a slight pressure from the back of the blade against it during use will keep the blade from moving too far back. The bearings should not rotate while the saw runs idle, but should begin to rotate the instant the cut begins.
- Most bandsaws are equipped with upper (above the table) and lower guide blocks (below the throatplate) or with ball bearing rollers. Guide blocks/ball bearing rollers play a critical role in the performance of your bandsaw and must be in top condition. Inspect them for wear or deep grooves and replace if necessary. Keep them adjusted so that the sides of the blade are supported but not pinched.

## Bandsaw blade terminology

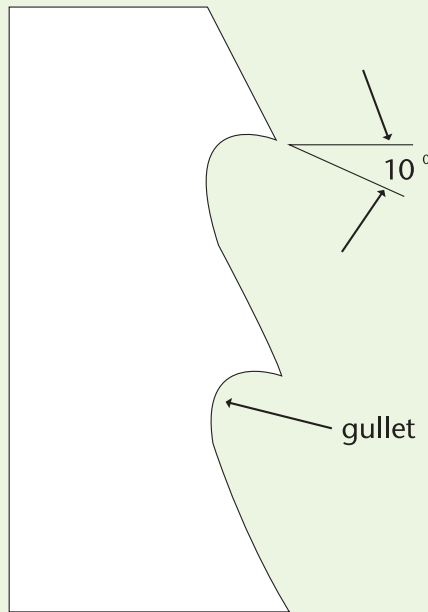

### Hook-tooth blade

A hook-tooth blade has a deep gullet and widely spaced teeth that have a 10° undercut face, which helps the blade cut well. The gullets tend to curl the chips. Hook-tooth blades, alternate set, are good for harder woods.

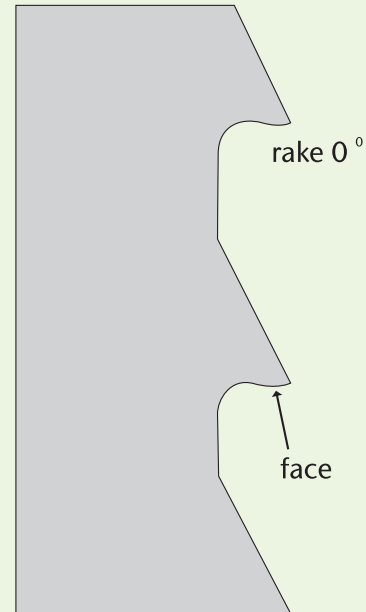

### Skip-tooth blade

A skip-tooth blade has a zero degree rake (a straight 90° tooth) and a sharp angle at the junction of the tooth and gullet. The large distance between the teeth aids in breaking up and clearing chips. Skip-tooth blades, raker set, are good for general-purpose woodcutting.

## Terminology

**Alternate set:** How the teeth are set—in an alternating right, left pattern.

**Gauge:** The thickness of the material used to fabricate the bandsaw blade.

**Gullet:** The space within the curved area between two saw blade teeth. This space serves to remove chips.

**Kerf:** The slot created when a cutting tool parts through material.

**Rake angle:** The angle that the tooth face makes with respect to a perpendicular line from the back edge of the blade. The angle is positive when the tooth angles forward in the direction of the cutting action and negative when it angles backward from the direction of the cutting angle. A hook-tooth blade has a positive rake of 10 degrees.

**Raker:** A pattern of offsetting the teeth, one tooth right, one tooth left, one tooth unset. (Also referred to as *raker set* or *raker tooth*.)

**Set:** The bending of bandsaw teeth to right and left of center. The set allows for clearance of the back of the blade as it cuts, which enables the blade to cut straighter and to clear chips from the kerf.

**Tension:** The direct pull in pounds on the bandsaw blade.

**TPI:** Teeth per inch, also referred to as *pitch*.

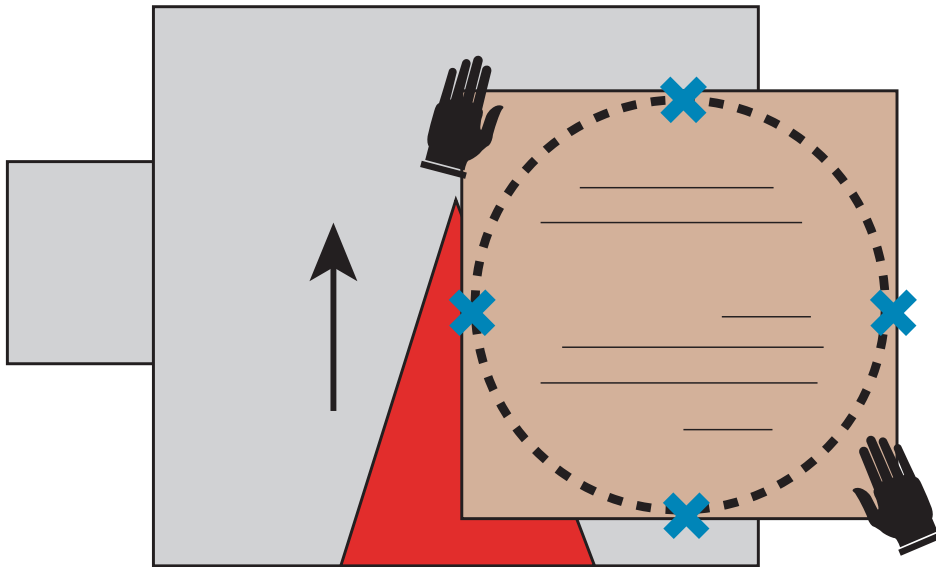

Figure 2. Position your left hand behind the sawblade and your right hand outside the danger zone as you cut a bowl blank. The Xs represent the four places where the blade will exit the wood, potentially making the bowl blank jump forward.

- Bandsaw blades, by their nature, are flexible, so the greater the distance between the upper and lower blade guides, the greater the chance the blade has to flex or develop a bow while cutting. Any maladjustment of the blade guides will only exacerbate the problem. If the guides are adjusted too far forward, the set of the teeth will be removed. If they are adjusted too far to the rear, or set too loosely, the blade won't steer properly.
- Make sure the throatplate does not have an overly large opening. An opening that has become too wide can cause a small piece of wood to fall into the opening, get caught, and possibly break a blade.
- An additional safety consideration is the distance between the top of the wood and the blade guard. When cutting bowl blanks of uneven thickness, that gap might be significant for part of the cut. Adjust the guard to be as close as possible to the top of the wood.

### Bandsaw blades

Blade type and width are important. Make sure the blade you use is capable of cutting the radius required for each size bowl blank. It is good practice to install a bandsaw blade that will allow at least three teeth to be in contact at all times with the material being cut.

The teeth on bandsaw blades are manufactured with a *set*, each tooth offset alternately right-left-right-left. This set is important because it produces a kerf that is wider than the thickness of the saw blade, which allows for clearance between the wood and the blade so that the blade does not bind. This clearance also gives the blade the ability to cut along curved or circular lines. A blade that has lost its set (a dull blade) will not cut properly and will overheat, weakening the blade and burning the wood.

For cutting large chunks of green wood, a 3 tpi, ½"- (13 mm-) wide blade is a good size that will hold up

well to heavy use. For cutting smaller stock, a ¾"- (10 mm-) wide, 4 or 6 tpi works well. Bandsaw blades for cutting wood are available in hook-tooth or skip-tooth configurations. (A standard-tooth blade is a good choice for cutting thin stock or non-ferrous metals.)

Hook-tooth blades, available in alternate or raker set, have a deeper gullet than skip-tooth blades. Their positive-tooth rake cuts more aggressively than a comparable skip-tooth blade. The deep gullet works well for eliminating shavings when cutting thick, green wood. A ¾"- or ½"-wide skip-tooth blade, alternate set, is a good selection for general resawing, cutting round sections to length, or cutting bowl blanks.

For inexperienced bandsaw users and for cutting soft wood, I suggest using a blade with a skip-tooth design, raker set.

### Deconstructing an accident

Woodturners primarily use the bandsaw to cut bowl blanks, so it's not surprising that many bandsaw accidents occur while performing this operation. Cutting bowl blanks involves both ripping cuts along the grain, as well as cutting across the grain; it is important to understand the effect this change in grain direction has when cutting round bowl blanks. Ripping cuts require more force than crosscuts because the blade is pushing into endgrain fibers. In crosscut operations, the blade feeds freely with little operator effort (assuming the blade is sharp and the bandsaw is set up properly). The change of grain direction is a leading contributor to bandsaw injuries while cutting bowl blanks—the operator does not take into consideration the difference in the amount of push required. If a dull blade is added to the equation, injury is even more likely.

Let's examine a common bandsaw accident in order to understand what went wrong. In almost every accident, the saw blade exited the wood at one of the points near the edge (*Figure 2, blue Xs*) while the operator's hand was positioned in the danger zone. Just slightly before the blade exits a piece of wood, resistance abruptly ends, the wood jumps forward (still pushed by the operator), and the operator is unable to react quickly enough to stop his or her hand from being cut, if it is in the danger zone. Keep your hands away from the danger zone and be aware at all times when the blade is about to exit the wood so that you can ease up on the pushing pressure and cut the last bit of wood with a slow, controlled push.

Forcing a bandsaw blade through the cut with a dull blade stretches the back of the blade and compresses the front edge, allowing a bow to develop in the blade while attempting curved cuts. Once the blade begins to develop a bow, it becomes even harder to follow a curved line; there is so much pressure on the inside of the cut that the blade will have a tendency to cut in a straight line instead of following the curve of the bowl blank. The more force the operator applies to turn and cut the blank, the more the blade begins to bow and an accident is in the making.

Most turning blanks made from log sections are rectangular or square in shape, so when cutting a circular shape from the half-log, there are two or four points during the cut where the blade is close to the edge of the wood. Not coincidentally, these points are where the grain direction change occurs and where nearly all accidents happen. Be aware at all times when the blade is about to exit the wood and ease up on the pushing pressure.

## Safe cutting method

*Figure 2* illustrates the method I advocate for cutting bowl blanks. Notice that the operator's left hand is behind the saw blade as the blank is rotated toward the danger zone, where the blade is most likely to exit the blank. In the event that the blade exits the cut at that point, the operator's left hand has already been placed beyond the cutting edge of the saw blade, completely out of harm's way. Having a slight bend at the left elbow keeps the operator's arm well away from the blade. By following this method of cutting blanks and planning your hand position in advance, chances of being injured while cutting bowl blanks will be significantly reduced.

## Other considerations

Always ensure that bowl blanks (or any wood being cut) sit flat on the table of the bandsaw. Any gap between the blank and the table where the blade enters the wood will cause the wood to be pulled toward the table with enough force to damage or break the blade.

It is common practice to mount a fixture to the bandsaw table that utilizes a stationary pin to cut circles. A divot is created in the center of the blank, which is then placed over the pin. The stock is pushed through the blade while rotating on the pin, and the result is a near-perfect circular shape. This setup works fine for thin stock, but never, under any circumstance, should you attempt to cut bowl blanks while using a pin guide such as the one described. The bowl blank

## Cutting large-diameter logs

When cutting round stock on a bandsaw, unsupported material can be caught and rotated, pulling it into the blade with a good deal of force. This can result in serious injury and/or jamming the blade, stalling the bandsaw motor, or kinking the blade, rendering the blade useless.

For small-diameter round stock, a simple V block works well. For larger stock, V blocks do not sufficiently support and stabilize the log, so for safety, I use a modified sled.

For the bottom two boards, use 2" x 4" lumber, screwed to the miter gauge at 90°. To that, attach with screws 2" x 2" cross pieces, spaced as wide apart as possible, yet still making contact on both sides of the log. This spacing may need to be adjusted for larger or smaller diameter wood.

Some logs are crooked or have knots and do not rest in the carrier as safely as I would like. For those, I use a bar clamp to hold the log securely to the fixture. Placing screws into the log and the carrier is another option, as are wedges hot-melt glued onto the log and carrier.

A refinement to the fixture would be to use ½" plywood for the bottom instead of the 2" lumber, which would allow cutting of even larger-diameter pieces.

—John I. Giem



## Ripping wide stock

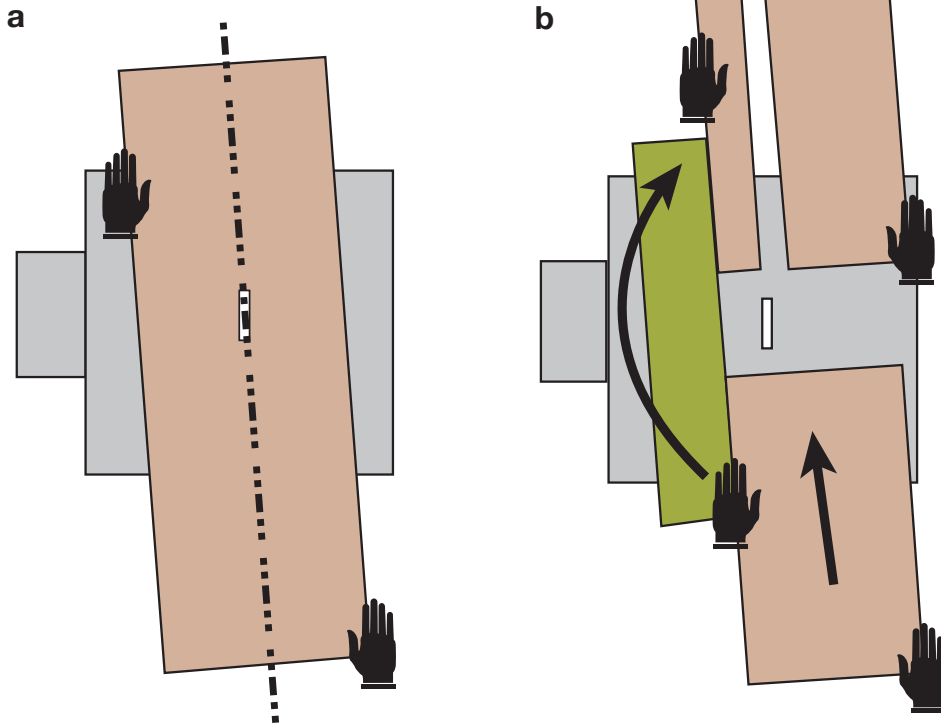

Figure 3. (a) The operator's hands are placed correctly to avoid the danger zone. (b) If cutting a long board, the cut can begin with hands placed as shown in the lower portion of this illustration. As the cut proceeds, move your left hand to the back side of the blade, as shown on the top of this illustration.

## Ripping narrow stock

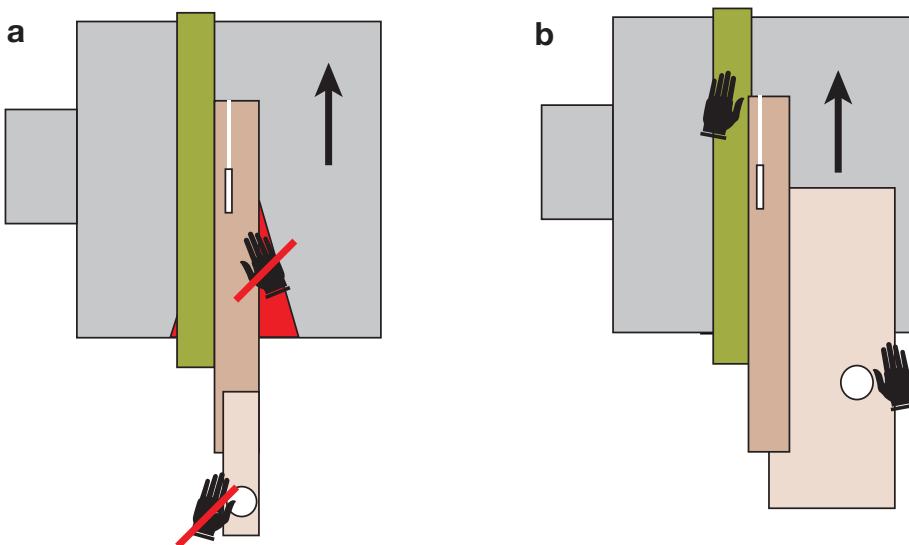

Figure 4. (a) The operator's hands are not positioned correctly even though a push stick is employed. (b) The operator is using a push stick (depicted in light brown) and has placed both hands correctly to avoid an accident.

must be allowed to “float” on the table, which helps compensate for blade drift and flex. Turning blanks do not have to be perfectly round—that’s the lathe’s job.

If you find yourself in a situation where the blade is having trouble following the desired line and the blade is in danger of exiting the blank, don’t continue to force the cut. Ease up pressure on the cut, be sure your hands are out of the danger zone, and carefully steer the blade out of the side of the blank.

## Ripping wide stock

Woodturners often find it necessary to cut large blocks of wood into smaller pieces for pen blanks, furniture legs, or bottle stoppers. Properly tuned, the bandsaw is ideal for this. It provides a better yield and is safer than using a table saw.

Very few bandsaw blades cut in a perfectly straight line, though, even when new. That tendency to cut on either side of a straight line is known as *drift*. To compensate for drift, a bandsaw should be equipped with a fence that is capable of being adjusted to compensate. An easy way to determine the amount and direction of drift in a bandsaw blade is to draw a straight line, parallel to one edge, on a piece of flat scrap wood (Figure 3, a). As you guide the blade through the cut, notice the angle of the stock in relation to the square table. Set your fence to that approximate angle and make another test cut, keeping the stock against the fence and the guides close to the wood. With minor adjustments of the fence, the blade will cut cleanly through a long piece without binding or drawing the stock away from the fence. You are now ready to rip your stock to width (Figure 3, b).

Pay attention to the hand positions in the diagrams. Similarly to cutting bowl blanks, the left hand is moved

to a position behind the blade, while the right hand is never in the path of the blade. In the event of a slip, there is little danger of operator injury.

### Ripping narrow stock

When cutting a board into narrow stock, your hands can come dangerously close to the bandsaw blade. It is good practice to use a push stick to guide your work through the blade. Even then, it is important to position your hands away from the danger zone. *Figure 4 (a)* shows the operator using a push stick; however, both hands are potentially in the blade's path.

A safer method is placing your left hand behind the blade to secure the stock, while your right hand is safely off to the side of the blade holding the push stick (*Figure 4, b*). By the time the cut is completed, your right hand will be beyond the cutting edge of the bandsaw blade as well, out of harm's way.

There are many circumstances where a small piece of wood requires cutting on the bandsaw, and there are many ways to safely cut each piece. For example, a wooden clamp is useful for holding small objects safely while they are being trimmed to length. You could use a piece of scrap wood and use hot-melt glue to temporarily affix the small item to the larger piece of wood, sacrificing the scrap wood instead of your fingers.

### Cutting round stock (cylinders)

Another cut frequently employed by woodturners is cutting cylinders, such as tree limbs, into manageable lengths. Cutting cylinders on the bandsaw, however, is a potentially dangerous operation. Aggressive saw blades may work just fine for cutting bowl blanks, but that same blade will cause an unsecured round piece to roll rapidly into the blade, possibly carrying the operator's hands with it. There is also the possibility that the workpiece will

roll with enough force to break the saw blade. Even something as small as a ½" (13 mm) dowel rod can break a bandsaw blade.

There are several ways to prevent injuries when cutting cylinders. (A chainsaw may be a safer alternative when cutting large-diameter logs.) A shopmade V block will help stabilize smaller pieces and allow them to be cut safely (*Figure 5*). A miter gauge, in combination with the V block, is a good choice as well. Never attempt an unsupported cut on round stock. The material to be cut must be sitting flat on the bandsaw table.

A common, and incredibly unsafe, mistake made by some woodturners is attempting to shorten a too-long tenon on the bottom of a bowl blank using the bandsaw. The saw *will* pull the stock down to the table, rolling the round bowl at the same time. Even the most experienced bandsaw operator should never attempt this cut.

Do not attempt to cut a sphere using the bandsaw unless you know how to correctly and securely attach it to a jig.

### A last word of caution

There are two categories of woodworkers who receive the most injuries, beginners and, oddly enough, the most experienced operators. It's possible that experienced operators begin to take the bandsaw for granted since they've made thousands of cuts without incident. It is easy to become complacent and gradually let your guard down. Always use common sense and think safety first. If it is used properly, you will discover the bandsaw is a versatile, safe machine.

### Suggested References

*The Band Saw Handbook* by Mark Duginske, Sterling Press, 1989.

*The Bandsaw Book* by Lonnie Bird, Taunton Press, 1999.

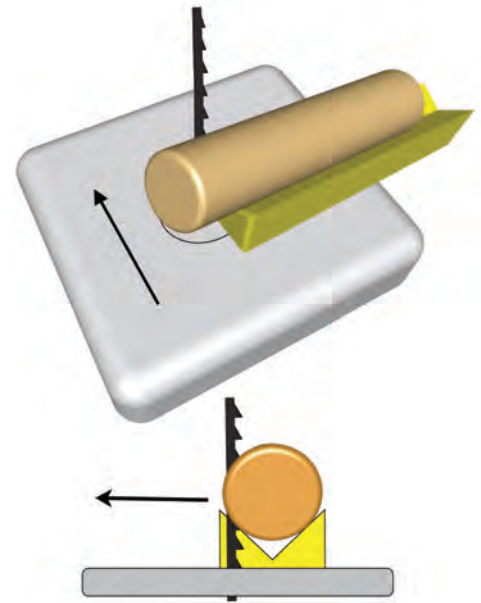

Figure 5. Never cut a cylinder without supporting it in a jig of some sort. This cylinder is correctly supported in a V-block jig. (Do not attempt to cut spheres using a bandsaw without the use of a proper jig—a V block is not sufficient support for cutting spheres.)

---

*Keith Tompkins is a professionally trained cabinetmaker, experienced in all phases of industrial woodworking, including CNC programming. In addition to operating a successful woodturning studio, he is currently employed by the State of New York as an Industrial Training Supervisor, responsible for training inmates at a maximum-security facility to work in a high-tech industrial woodworking environment. He may be contacted at keithptompkins@frontiernet.net or through his website, keithptompkins.com.*



# Bandsaw: Safe Practices with Green Wood

*Alan Lacer*



AW 19:3, p60

Give me a lathe, a grinder, and a bandsaw and I'm a happy woodturner. But despite the importance of lathes and grinders, we sometimes overlook the bandsaw's role in turning. Here are some bandsaw tips for a wide range of turning applications—from preparing stock for small tops to larger green wood bowls.

### Sensible bandsaws for woodturners

I've had poor luck with bandsaws with smaller than 14" wheels, and no luck at all with the three-wheel models and resaw bandsaws with wide blades. My recommendation is a 14" or larger saw—preferably with a minimum of 8" under the blade guide.

One excellent choice for a woodturner turning modest-sized pieces is to purchase a 14" saw with the optional riser block kit (allowing approximately 12" under the guides). There also are a number of 16", 18", and 20" saws capable of doing great work for the turner, but costs escalate.

I steer most turners away from the large classic bandsaws of 30" and 36" because the forces are so great and the saw is too unforgiving when something goes wrong. For 14" saws, I prefer at least a one-horsepower motor for the gusto required to cut through wet wood. And I like a tilting table for tasks including sawing off corners of large turning squares and cutting tapered bowl blanks.

## Bandsaw blades for turners

- For green-wood cutting, I prefer a skip or hook-tooth blade with as few teeth to the inch as I can find—usually 3 or 4 teeth per inch (tpi). Both tooth styles have advantages and disadvantages. The hook tooth does not clog as quickly, but the aggressive cut pulls stock into the blade. The skip tooth is gentler to operate, but clogs more frequently. Try both types to determine which suits you best; you'll like either one better than a regular blade.

- I don't recommend narrow blades of 1/4" or less, nor blades greater than 1/2". For preparing bowl blanks, turners don't need a narrow blade to cut exactly on the circumference. However, we want a blade that is not prone to jamming when cutting a radius. In balance, a 3/8" or 1/2" blade satisfies turning work.

- Blade thickness also is a concern for resistance to twisting and metal fatigue. Generally I avoid any blades less than 0.025" thick. For my 20" bandsaw, I

prefer something closer to 0.030".

I purchase blades from a local saw shop that welds them to length from good quality basic stock. If you go through a lot of blades and have a frugal bent, consider learning how to silver-solder blades from rolls of coil stock.

But what about the low-tension, bi-metal, or carbide-tipped blades? Because I often cut wood with bark attached—which dulls blades—I can't justify the more expensive blades in these categories for rough-cutting stock.



### Options and accessories

- Good light to shine directly onto the cutting area.
- Brush for the lower wheel to minimize build-up on the tires.
- A brake, which is a wonderful safety feature usually found on 20" or larger saws.

### Bandsaw safety

I probably know more turners injured at their bandsaw than at their lathe. The message: Learn the saw's habits, develop sound practices, and acquire a healthy respect for this machine.

## Safety tips in the Red Zone

While teaching bandsaw techniques, I recommend drawing or painting a 1"-wide strip on the bandsaw table that extends from the blade to the edge of the front table. Hands and arms must stay out of this zone. Unless using a pushstick, never push with the hands or fingers in this zone.

To reduce exposure to injury, I work from the side when cutting bowl blanks, turning the piece into the blade rather than pushing.

One more suggestion: Develop a routine to pull the stock through the bandsaw rather than pushing. Doing so reduces the chance of injury.

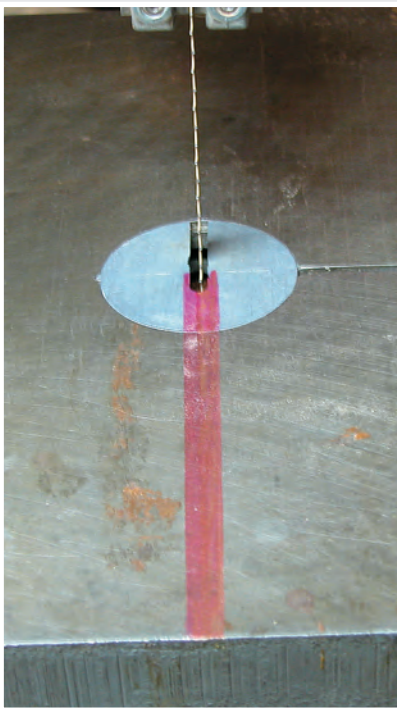

Who is probably most at risk for a bandsaw accident? Two prominent groups generate the most accidents: the novice who does not understand the bandsaw's behaviors and the seasoned veteran who thinks he or she has mastered all and therefore can't get hurt.

I operate from two essential rules. First, hands and arms must stay out of the Red Zone—the area in line with the blade. See the box at *left* for more details.

Second, work with supported stock—not stock that wobbles, rolls or flips while cutting. Just as in turning wood where an unsupported edge causes a dig-in, serious bandsaw accidents happen with lightning speed

when the work is not supported below the cut.

I know a lot of turners like to crosscut short, round objects on the bandsaw. But there are serious risks here unless you take precautions. If larger than 3" in diameter, I prefer to crosscut stock with a chainsaw.

It is possible on some sizes to rig up V-blocks to cradle the round stock. If the round stock is small (under 2") and shorter than the table is wide, I suggest securing the piece in a parallel (handscrew) clamp that stays flat on the table as shown *below*.

For making multiple blanks 2" or smaller, crosscut stock with your bandsaw miter gauge. Clamp smaller pieces of wood



To crosscut short round stock, securing material in an adjustable parallel (handscrew) clamp is a solid solution.

against the miter-gauge fence and cut away—a good technique to remember for making multiples.

The problem with crosscutting round stock is that on entry, the piece tries to roll like a wheel—pulling the work quickly into the blade and sometimes twisting the blade. Either of these situations can result in a broken blade or worse—an accident caused by shooting the wood from the saw or pulling your body parts into the blade.

One additional note: It makes my hair stand on end when I see or hear about a turner going to the bandsaw to cut the waste off the bottom of a turned bowl. This sounds like an emergency room visit in the making. A better plan: Remove the nib off the lathe with a Japanese pull saw.

### **Bandsaw bowl stock**

Because bowl turning is still the most popular interest, let's review the process of bandsawing a small log to produce a face-grain bowl.

I recommend crosscutting the log to length (slightly longer than the diameter) with a chainsaw or even a hand bow saw. Next, halve the log using wedges and a sledge hammer, a chainsaw, or bandsaw.

At the bandsaw, there are several options for halving a log. One is to cut into the side of the log (end grain on table) as shown *above*. I suggest this technique on logs 6" or larger in diameter and no longer than the height under the upper blade guide.



With 6"-diameter or larger stock, you can bandsaw logs upright to halve the material. Note safe hand position.



A recommended ripping procedure: The downward pressure of the bandsaw blade reduces the tendency of the log to roll side to side.

Another strategy is to cut head on to the end-grain as shown at right—truly a ripping cut. This cut on supported wood avoids the danger of the piece rolling like a wheel as noted in crosscutting. If using this method, I recommend looking for a face of the log that has support on the bandsaw table along the entirety of the cut. Also, the face of the log that first contacts the blade should be as flat as possible to maximize support under the blade.

Next, cut the half log into a disc. The safest way I have found is a cutting template attached to the curved section of the half log.

I recommend making a set of patterns for the smallest bowl you think you will ever turn to the largest capacity of your lathe. Patterns from 1/4" plywood or hardboard are ideal. Make a set in half-inch increments, drill a hole through the center to accept a nail, and identify the size of each template as shown at *top right*.

### **Bandsaw with a template**

Select the appropriate template, nail it to the half log (flat face down on the bandsaw table) and cut around the outside of the template as shown *below right*. Don't try to cut the circumference in one pass—it's too easy to jam the blade or even twist it. I nibble away with 6 or 8 cuts that appear to be straight.

If you're new to bowl turning or you're turning at a lightweight lathe, take your time to make the blank round; doing so reduces effort at the lathe. For mounting stock to the faceplate, use the same template to mark the center on the flattened face.



Spend a few minutes to make a set of cutting patterns, shown above, for your lathe's swing capacity. The 8" pattern is shown at right on a birch log.

I can think of no other saw that is so versatile as the bandsaw. It easily rips, crosscuts, cuts circles and arcs, works logs or other thick stock, and cuts angles—all quietly and effortlessly compared to other power saws.

But just like other power tools, the bandsaw demands full attention and control. Focus on the task at hand—not your lathe work—while bandsawing.



Alan Lacer ([www.alanlacer.com](http://www.alanlacer.com)) is an American Woodturner contributing editor. He lives near River Falls, WI.

# Chainsaw: Safety Gear, Safe Operations

A. J. Hamler

The chainsaw is undoubtedly one of the greatest labor-saving devices for woodturners who gather their own stock. Fast, convenient, and efficient, a chainsaw can fell a tree and transform the downed trunk into dozens of pieces of turning stock within minutes. It's especially adept at preparing blanks for natural-edge bowls.

This convenience, though, carries risk. If used improperly, the chainsaw can cause particularly devastating injuries. The U.S. Consumer Product Safety Commission (CPSC) says there are 30,000 to 40,000 chainsaw-related injuries reported annually. For accident details, see the sidebar *opposite*.

Accidents have a variety of causes. As with all powered machinery—from cutters to cars—failing to heed proper usage guidelines and safety precautions is always a factor, as are fatigue and distraction. Loss of balance while cutting causes numerous accidents, while being struck by falling limbs and tree trunks causes non-saw chain contact injuries.

*"...saw kickback can move in a 90-degree arc—the distance from the workpiece to the operator's face—in only one-tenth of a second."*

Although it's an incredibly useful tool for woodturners, an improperly used chainsaw can be an accident waiting to happen.

Other causes are starting the saw while holding it by hand, carrying the saw while it's running, using a saw while on a ladder or in a tree, over-reaching and cutting overhead, being unaware of bystanders, cutting between the feet while standing on a log, or simply losing control of the saw.

Fully 85 percent of all injuries involve contact with the moving saw chain, and the CPSC estimates that the average injury from saw chain contact requires 110 stitches.

## Kickback, an old nemesis

Most chainsaw injuries occur to the legs and arms, as shown in the pie chart *opposite*. Kickback is a violent action that sends the chainsaw upward and back in an arc directly at the operator (oftentimes at the shoulders or head). Kickback most often occurs when the moving teeth at the tip of the saw (usually the teeth on the upper quadrant of the rounded tip) unintentionally make contact with an object.

If this contact is solid enough, the forward motion of the teeth is slowed and the kinetic energy of the chain is transferred to the body of the saw itself. If you aren't holding the saw correctly, the kickback flips the saw in the opposite direction from that of the teeth, and it does this far quicker than your ability to react to it. A publication from the University of Minnesota Extension Service shows that a saw kickback can move in a 90-degree arc (the distance from the workpiece to the operator's face) in only one-tenth of a second. Scary-fast.

Kickback-causing contact occurs in a variety of other circumstances, such as cutting with a dull chain or running the chain too slowly. Twisting the saw while cutting can make the teeth bind at the tip, also initiating a kickback. But it's not just contact with the workpiece itself that

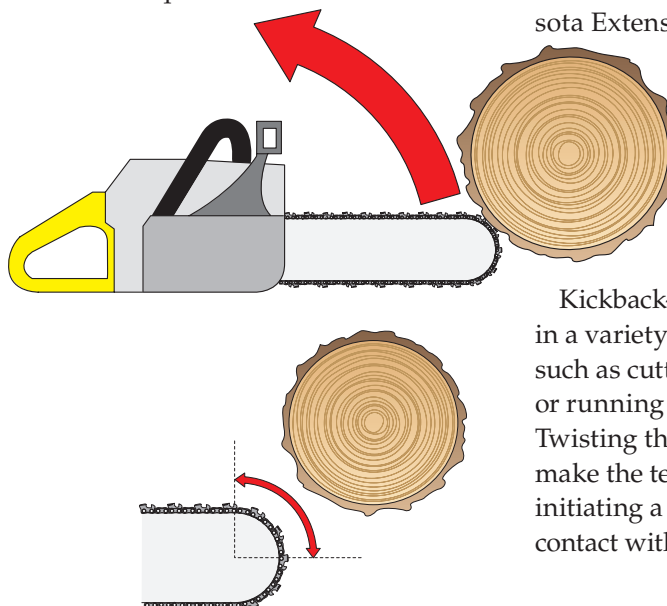



Safety clothing and gear, like this offering from Husqvarna, can help avoid or minimize injury. From left: Heavy-duty jacket, chaps, leather gloves, helmet system with face shield and hearing protection, steel-toe boots.

can cause kickback. In fact, kickback is more likely when the tip of the saw unexpectedly contacts an object beyond the workpiece. This can be a rock, log, or even the ground.

Fortunately, due to voluntary standards adopted in the mid-1980s, today's chainsaws incorporate a number of improvements to help minimize danger. Manufacturers have redesigned cutting chains to reduce kickback-causing friction, while tip guards and narrower bar tips reduce the amount of contact area at the saw tip. Almost all chainsaws now feature a chain brake that can be manually set or automatically activated by the motion of a kickback. Some systems activate through mechanical contact with the front hand guard or by the inertia of the kickback alone. See additional details in the drawing on page 54.

## 22 ways to play it safe

Avoiding accidents should be the number one consideration when using a chainsaw. Frankly, a load of great turning blanks won't do you any good if you're spending your time in recovery and rehab. The companion article "Bowl Hunting

with Mike" on page 56 gives you great advice on planning your cuts to make the most of the wood, but you also need to think through the potential hazards of each cut before you make it.

With that in mind, here's a checklist of safety practices for chainsaws. Nothing can completely eliminate accidents, but following these guidelines can help minimize their occurrence, or at least lessen their severity if they do occur.

1. Maintain your equipment in top-notch condition. That means efficient motor performance, sharp chain, proper chain tension, and sound handles. Examine the guide bar for straightness before each use, and do not use the saw if the bar is bent.
2. Read and follow all instructions in the instruction manual, paying particular attention to the special characteristics of your saw.
3. Replace an old saw with a model that has modern safety features. At the very least, replace the bar and chain with low-kickback versions.
4. Check your saw's safety features before each use.

## Inside the accident statistics

Breaking down the numbers, the U.S. Consumer Product Safety Commission (CPSC) notes that nearly half the injuries (about 43 percent) involve the legs, while almost as many (about 42 percent) occur to the arms and hands. The remaining injuries involve the head (7 percent), feet (6 percent), and upper-body (2 percent). Because of the way a chainsaw is designed to be held by the left hand and controlled with the right hand, injuries occur far more often to the left side of the body.

**Note:** Some spokespeople in the timber industry feel that any accident in the forest is unfairly classified as chainsaw-related.

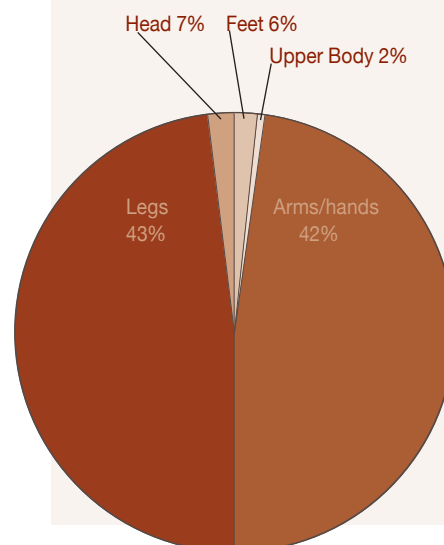

**5.** Wear protective clothing—heavy-duty chaps or pants, steel-toe boots, and thick gloves. Never wear insubstantial footwear such as sneakers.

**6.** Use personal protective gear—safety glasses (always), face shield (if needed), hearing protection, and helmet. Consider purchasing a full helmet system that includes both face shield and hearing protection. Safety glasses should be worn under the helmet, as specified by ANSIZ87.1 standards.

**7.** Avoid dangling items that a chain can grab: loose sleeves, key chain, belt, bootlaces, long hair, and so on.

**8.** Check the area for hazards. Be sure that the saw tip will not contact any object near a workpiece while cutting. Take extra care and double-check your footing if conditions are wet, muddy, snowy, or icy.

**9.** Never cut alone. By the same token, be aware of any other people (and pets or livestock) and keep them away from the cutting area.

**10.** Never cut if you're tired, preoccupied, distracted, or in a hurry. Understand the effects of any prescription or over-the-counter medications you take, and don't cut if these medications cause drowsiness. No alcohol. Ever.

**11.** Always start the saw on the ground, not handheld. Use both hands when starting the saw, as shown *above top*. Before attempting to start the saw, be sure the chain brake is engaged. Never wrap the starter cord around your hand when pulling.

**12.** Always use both hands to control the saw when cutting. Never attempt to cut single-handed.

**13.** Don't stand in the line of cut or lean your head over the line of the guide bar. Always stand to the left of the cutline, and don't allow anyone else to stand in the line of the cut.

**14.** If you're working on a slope, brace or wedge the log if possible to prevent rolling. Always stand on the uphill side to avoid rolling logs.

**15.** Never carry the saw while it's running. (And, of course, never run with the saw!)

**16.** Don't overreach. If there's a danger of losing your balance, move to a more secure location. Never cut overhead; in fact, never cut higher than waist level.

**17.** Cut only while standing firmly on the ground, never from a ladder or up in a tree.

**18.** When removing branches from a downed log, cut with the guide-bar base whenever possible, not the tip.

**19.** Don't stand on a log while cutting, and never cut between your feet.

**20.** When making deep cuts, use a wedge to keep the kerf open. This helps prevent the saw from binding in the cut, reducing the potential for kickback.

**21.** If you need to refuel during a job, allow the saw to cool down before gassing up.

**22.** Trust your instincts and stop working if a cutting task feels overly difficult or if you're unsure about your ability to complete a cut safely.

*You can view on-line safety videos at [stihlusa.com](http://stihlusa.com) (follow links under information) and [usa.husqvarna.com](http://usa.husqvarna.com) (follow links under chainsaws). For additional tips on safe use of chainsaws, see [forestry.about.com](http://forestry.about.com).*

---

*A. J. Hamler ([aj@ajhamler.com](mailto:aj@ajhamler.com)) writes about woodworking topics from his home in Williamstown, WV.*



Hold your chainsaw firmly on the ground when starting. Handheld starts are dangerous because you risk losing control.



A chainsaw is safest when used near ground level. Never use a chainsaw above shoulder height.



Use a polymer wedge (available from a chainsaw store) to keep the kerf open in deep cuts. If you accidentally knick the polymer wedge, you won't damage the chain.



# Chainsaw: Best Practices for Bowl Hunters

Mike Mahoney

In 20-plus years of operating a chainsaw, Mike Mahoney has never had an accident (knock on a lot of wood). Mike thinks that if you are safety conscious, you can find great pleasure in harvesting your own turning stock.



The chainsaw is as important to me as the lathe. It helps me make my object to my specifications as compared to buying wood that is already dimensioned from a wood dealer.

The chainsaw is a must-use tool for woodturners. It gives us the ability to find beautiful local turning stock that is free or nearly so. For many of us, local timber also defines our work. (I rely on Utah's silver maple; Dale Larson is known for the madrone that grows near his Oregon home.)

Before you pick up a chainsaw, a safety clinic from an experienced trainer is important. I feel strongly that a chainsaw safety talk by a trained instructor should be part of the annual programming lineup for all chapters.

## Shopping for a chainsaw

I recommend always purchasing a saw from a chainsaw dealer. Discount stores will not provide the warranty and maintenance that are crucial for your safety and your saw's performance. Saw dealers also provide information on chain types that may be specific for your cutting needs and will recommend a sharpening service as well.

There are three types of saws for woodturners:

1) Lightweight saws have a bar of 8–12". These are good for cutting branches up to 10".

2) Middleweight saws have a bar 14–20". These are great for cutting branches and small trees up to 18" in diameter.

3) Heavyweight saws have bars over 20" and are generally reserved for the professional. I take 24" Stihl and Husqvarna saws to the woodlot.

## TLC for your chain and bar

A dull chain is dangerous and therefore the chain should never touch the dirt while cutting. Dirt is the major cause of dullness on a chain. The chain should also be snug to the bar so as to not derail while rotating but not so tight as to bind. Chains loosen as they get warm so be prepared to tighten them as you work.

The bar of the saw is often overlooked as a source of problems while cutting. If your saw bar has had significant use, the channel widens and becomes uneven. I replace or

### Your chainsaw should have these safety features.

Spark arrestor on gasoline models

Trigger or throttle lockout

Hand guard

Vibration reduction system

Chain brake

Bumper spikes

Chain catcher

Low kickback saw chain

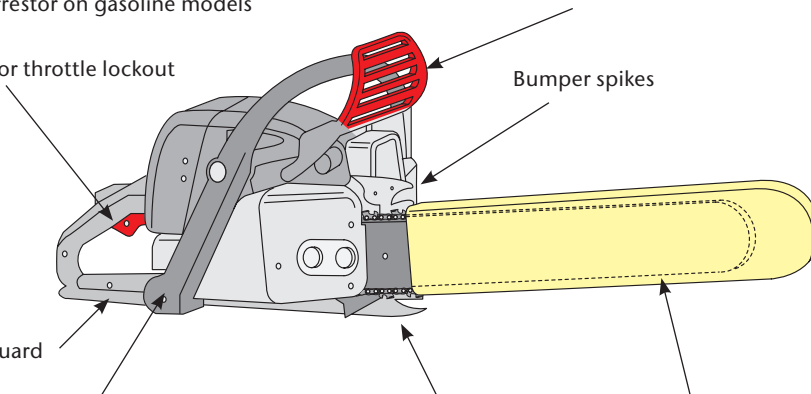

recondition my bars for every 10 chains I use. Most of this information is in the instruction manual, where you can learn a lot about the technical parts of your chainsaw.

## Be prepared

In addition to the safety rules on page 56, here are other guidelines I follow.

When I go to the woodlot, a helper accompanies me. We always bring two saws and many sharp chains. (Inevitably I will find a saw that won't start or run smoothly.)

Since I cut urban timber, I expect to hit nails and other foreign matter. That's why I always pack a few extra sharpened chains before I leave my shop. Being prepared with an additional saw and chainsaw saves time, improves efficiency, and reduces frustration.

## Having trouble finding wood?

A word about urban forestry: According to Sam Sherrill in his excellent book *Harvesting Urban Timber*, three to four billion board feet of lumber is discarded into landfills throughout the United States every year. Staggering!

Many people have no idea where to find these landfills, and when they do find them they feel they don't have permission to cut in them. I have been told that many municipalities will not let you cut there due to liability. A little research on the structure of your town's urban tree landfill facility will earn you some great rewards. Call and ask questions; the benefits of your time are worth the effort.

A nice turned gift to the authority in charge of the trees might make access easier as well. If all else fails, make friends with a professional tree trimmer.

—Mike Mahoney



1 Look for cracks emanating from the pith. These references will help you plan cuts.



2 After marking both ends of the log, make the first cut through the 18"-long log.



3 Separate the two blanks. Note how the log is elevated to keep the chain out of the dirt.



4 Beautiful! Urban timber harvest at its best. Note the powerful fiddleback grain.

Some other necessary tools include a mallet, wedges, grapple hook, bar oil, properly mixed fuel, bar wrench, chainsaw file, and a first-aid kit. Don't forget to take along several heavy-duty pencils or markers to sketch out your bowl profiles.

## The important first cut

The key to making a first cut is knowing the end product. A hollow form, for example, requires a different cutting approach than a salad bowl or natural-edge bowl. The photos at right illustrate cutting a log for salad and natural-edge bowls. The salad bowl opposite was turned from the silver maple trunk shown.

For efficiency, cut a series of cross-cuts the length of the diameter of the log. Then drive in a wedge to keep the kerf open so it won't collapse and pinch the blade. To keep the chain from touching dirt, use care not to cut all the way through the log. When you've finished a series of cuts, roll the log over and cut from the top to separate them.

Before you start cutting bowl blanks, you need a plan. Look for cracks emanating from the pith (Photo 1). If the log has no physical defects on its bark, this step dictates the direction your saw should follow.

Use your pencil or marker to sketch out the bowl profiles. Be sure to draw the lines of both ends of the log. Then properly support your log. Brace the log on both sides for support. The first cut is a flat cut that makes the blank easier to handle on the bandsaw when you return to your shop (Photo 2). The second cut (Photo 3) separates the salad bowl from the natural-edge bowl and reveals fiddleback grain (Photo 4).

Mike Mahoney ([latheguy@aol.com](mailto:latheguy@aol.com)) is a full-time woodturner and popular demonstrator who lives in Orem, Utah.

# Chainsaw Safety: A Stand for Sawing Blanks

Jerry Markowitz

This project has taken a long route to American Woodturner. First stop: Richard Stapley's British website (laymar-crafts.co.uk). There, Richard posted plans for a safer way to chainsaw turning blanks.

Jerry Markowitz, a member of the Bayou Woodturners from Kenner, Louisiana, found Richard's design on the Internet and added a few tweaks of his own. Because many bowl blanks dwarf his benchtop bandsaw, Jerry added a 4"-wide platform at one end so he can trim off the corners of bowl stock with his 16" electric chainsaw.

Put this chainsaw platform at the top of your "to-do" list so it's built before you prepare turning stock again. (Note to chapter program committees: Consider building these at an upcoming meeting.)

And the next time you have "just a couple of cuts to make," you'll be set up for a safer procedure.

## Build your platform

**1** From  $\frac{3}{4}$ " MDF or exterior plywood, cut seven pieces to 12x15". Cut V-shaped notches in one support section where dimensioned *opposite*. Drill  $\frac{1}{2}$ " holes through the stock where shown in the drawing. To ensure accurate alignment of the holes, use a stopblock on your drill press.

**2** From  $\frac{1}{2}$ " PVC pipe, cut 10 sections 3" long and two sections 6" long.

**3** Before you begin cutting the  $\frac{1}{2}$ x36" all-thread rod to length, place a  $\frac{1}{2}$ " nut on one end. (When you remove the nut, you will clean up threads damaged in the sawing process.) With a hacksaw,



cut two pieces of  $\frac{1}{2}$ " all-thread rod to 28".

**4** To assemble, follow the 4-step drawing *opposite*. First, thread a  $\frac{1}{2}$ " washer and a  $\frac{1}{2}$ " nut on one end of each of the all-thread rods, positioning where shown in **Step 1**. Slide 6"-long sections of PVC over the all-thread, then screw on another nut and washer 6" from the previous pair where shown in **Step 2**.

**5** Pass the rods through two of the notched supports (**Step 3**). Then thread another washer and nut pair on each end where shown in **Step 4**. Tighten the washer and nut pair against the supports.

**6** Continue assembling the jig as shown *opposite*, placing the pair of 3"-long PVC pipes between other platform supports as shown.

## Put the platform to use

Each time you use this platform, strap your timber to the supports with a band or web clamp.

Here are three tasks to use this platform to increase safety:

**Split logs.** As shown in the photo *above*, place split logs on the flat side of the platform.

**Unsplit logs.** Place unsplit logs on the V or notched side of the jig as show at right and the End View Drawing *opposite*.

**Bowl blanks.** Jerry's modification, shown *below right*, allows you to prepare bowl stock by trimming off the corners.

**Supplies:**  $\frac{3}{4}$ x48x36" MDF or exterior plywood;  $\frac{1}{2}$ x36" all-thread rod (2);  $1\frac{1}{2}$ x48" PVC pipe;  $\frac{1}{2}$ " nuts (28);  $\frac{1}{2}$ " washers (28); band or web clamp.

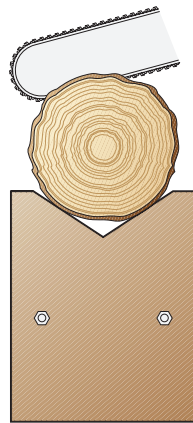
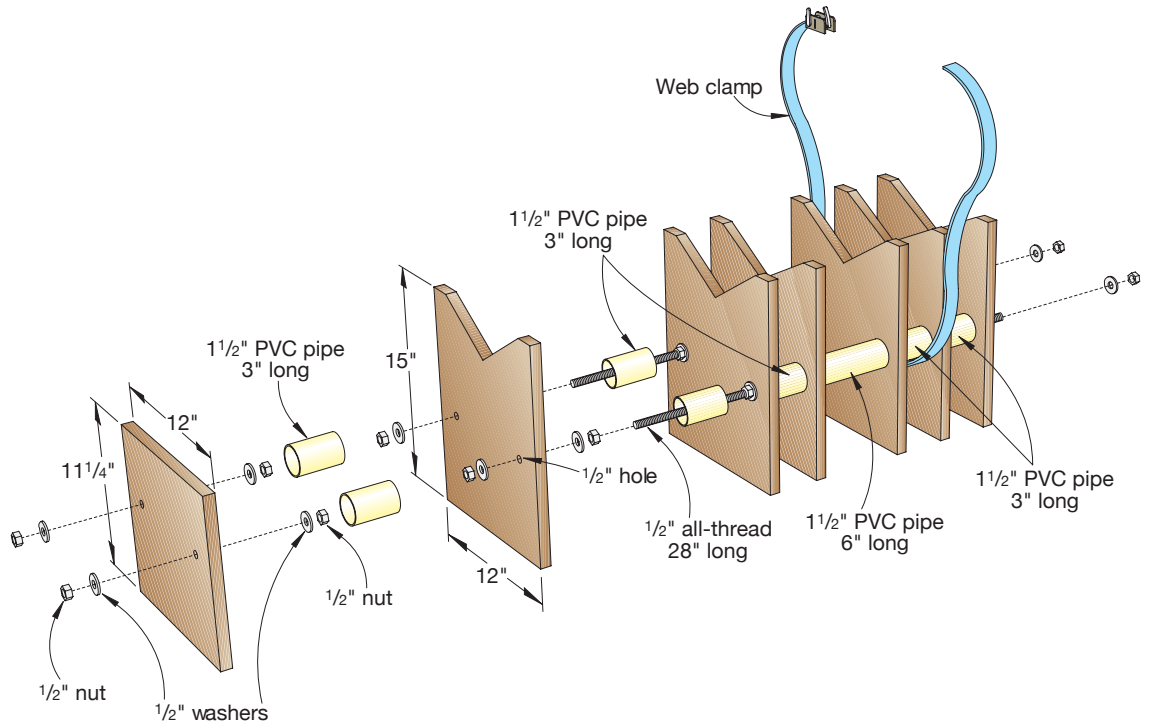
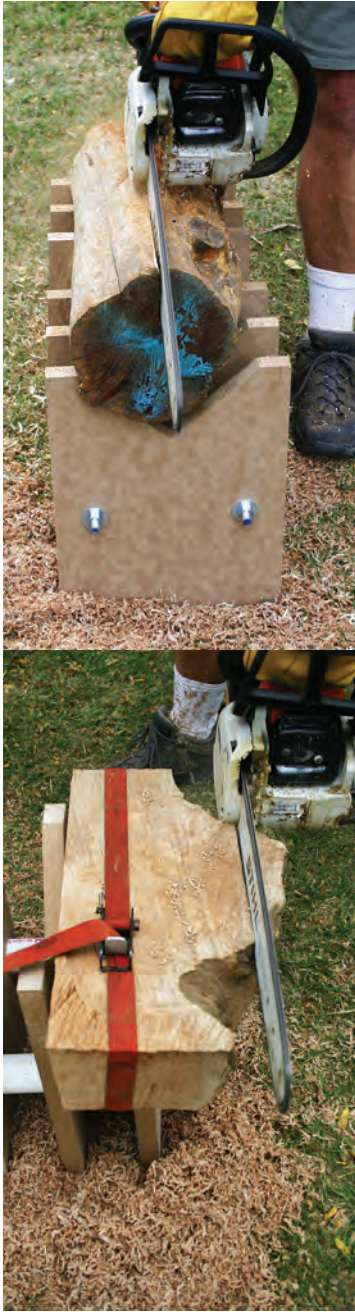

END VIEW

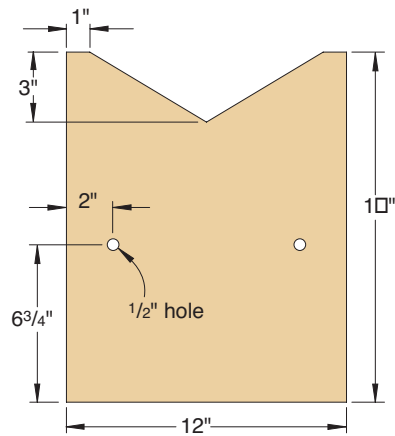

**Step 1 Thread nut and washer pairs**

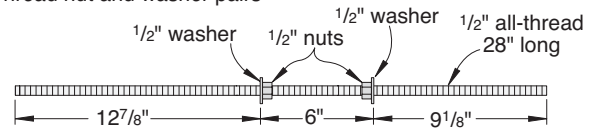

**Step 2 Slide 6 inch PVC into place**

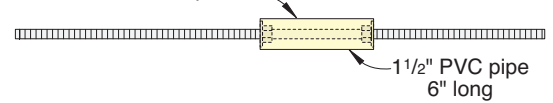

**Step 3 Add MDF supports**

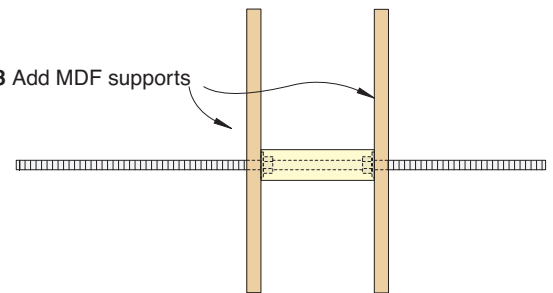

**Step 4 Thread washer and nut pairs on each end and tighten against MDF supports**

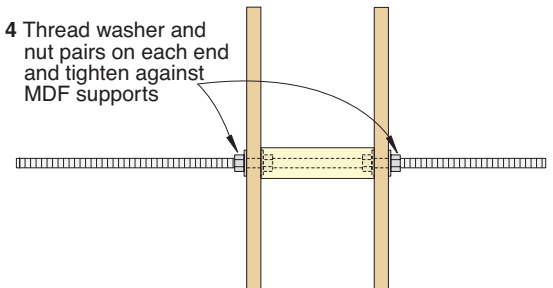

# Fitness in the Workshop

Howard K. Peters

---

Woodturning is an absorbing activity; often we find ourselves so fully engaged at the lathe that we are unaware of how much we are taxing the body. There are consequences to overusing the body this way. I see them as an amateur woodturner and as a professional physical therapist. Although I still have occasional “catches” in my amateur role, my professional side has figured out how to prevent the liabilities of improper physical positioning and movements. Physical comfort while working and freedom from disabling aches and pains when we’re done is really a safety issue that is best understood in terms of the ergonomic requirements of a workshop and the physical activities in it.

We all strive to avoid turning mishaps, rightly abhorring the loss of a piece. As well, we don’t assign our human form to scrap regardless of its condition. But all too often we forgo preventive measures and jeopardize our health, perhaps mistaking our priorities, perhaps not fully understanding how to do right by ourselves.

You are familiar perhaps from personal experience with the terms repetitive motion injury, overuse syndrome, and more specifically, carpal tunnel syndrome and golf and tennis elbows. All of these represent accumulative trauma with resultant microscopic tears and/or irritation of muscular or tendinous tissue. Controlling the pain and inflammation with medication often only masks the condition and is not the solution. Determining the cause and its prevention is. I have prevented most of that personally but in my enthusiasm I find myself during extended periods of time at my lathe (a

lovely Conover) trying to defy needed rest for my muscles. I feel it first as muscle soreness in my neck. Certain muscles of the body sustain static postures rather well while others do not. Try holding your arm out from your side for a minute or so. Backs and legs and even necks fare somewhat better but it is human nature to demand more, sometimes abusing our capabilities. We force our pliable body into submission, expecting it to comply; occasionally it rebels.

As beneficial as a cure can be, identifying the cause and then preventing the problem is the best approach. We must start with understanding some basics. We know that objects shouldn’t fall over and we try to prevent such occurrences. However we seldom take time to analyze why an object tumbles or not. Everything, person or object, has a center of gravity (CG). It is an imaginary point representing the object’s center of weight pulled so to speak toward the earth’s center. For earthly purposes we are all subject to this force. The CG lies within the confines of a stable object’s or person’s base of support or footprint. Picture a pyramid and you are picturing stability. A long cylinder resting on end is less stable. Its footprint is relatively small but so long as the CG remains directly above that footprint it won’t topple. A ball or an inverted cone have minuscule footprints. The former will roll with the least provocation and the latter won’t even stand up.

Look at your shop equipment—a good base or footprint? Of course. Much like that of a cube.

Now consider yourself standing in your shop. You’re more like a cylinder. If the CG gets outside of its footprint a

crash is imminent unless you can get the line of force passing through the CG back within its footprint quickly enough, like balancing a dowel on the end of your finger. If an object’s shape or position changes, the location of its CG also will change. In the human body its location depends on anatomical structure, posture, current position, and whether external weights are being supported. Because we are segmented our body is capable of numerous positions and our CG moves about much more than that of an inanimate object. What we do with our head and limbs necessitates considering the relationship of their individual CGs to our body’s main CG which may also be in motion at the same time.

Say you are pushed. You automatically will adjust your footprint by moving your foot or perhaps even jumping into a new position to keep your CG under control. Muscles contract rapidly for a moment, then relax as you regain your footing.

Now extend one arm outside your footprint. Here too you accommodate for the change in your balance by muscular contractions but these contractions are steady. Keep this up long enough and you will experience fatigue. Continue the practice and you will experience discomfort, so-called overuse syndrome, and finally disability.

When you bend forward at your lathe or other piece of shop equipment you unconsciously reposition your feet, thereby enlarging your footprint. Or you should. The more your CG shifts toward the perimeter of your footprint, such as when you lift or hold some object (tool piece of wood, etc.), the more muscular effort is

required to maintain overall stability. A wider stance places fewer demands on your muscular system.

What about those appendages of your segmented body that have their own CG in relation to the whole body's CG and base of support? Cantilevering or moving a limb outside the footprint's perimeter, or even tilting your head on its own base of support (shoulders), calls on dynamic postural changes of those segments and muscular adjustments of the rest of your body. Maintaining any posture requires countering muscular activity and presents potential muscular fatigue. Something as simple as the focal length of your eyeglasses can affect head and neck posture adversely, hence your overall posture. Consider the constant work required by back muscles to compensate for the forward displacement of the CG that having a bit of a belly entails. Now picture yourself leaning over your lathe, taking the final passes on the inside of a deep bowl.

Rhythmic or at least occasional changes of position reduce the buildup of muscular fatigue, which is best relieved before muscle discomfort, twitches, or spasms signal trouble. Recognize the cause and you are forewarned. You can prevent overuse symptoms and avoid chronic, disabling conditions. The body works most efficiently when it can move freely and in a relaxed way. Skill in any activity demonstrates this, making challenging maneuvers seem effortless.

I recently self-published a book, *The Flexibility Manual*, about a new technique of stretching to regain and maintain the physical mobility we all have relinquished since childhood.

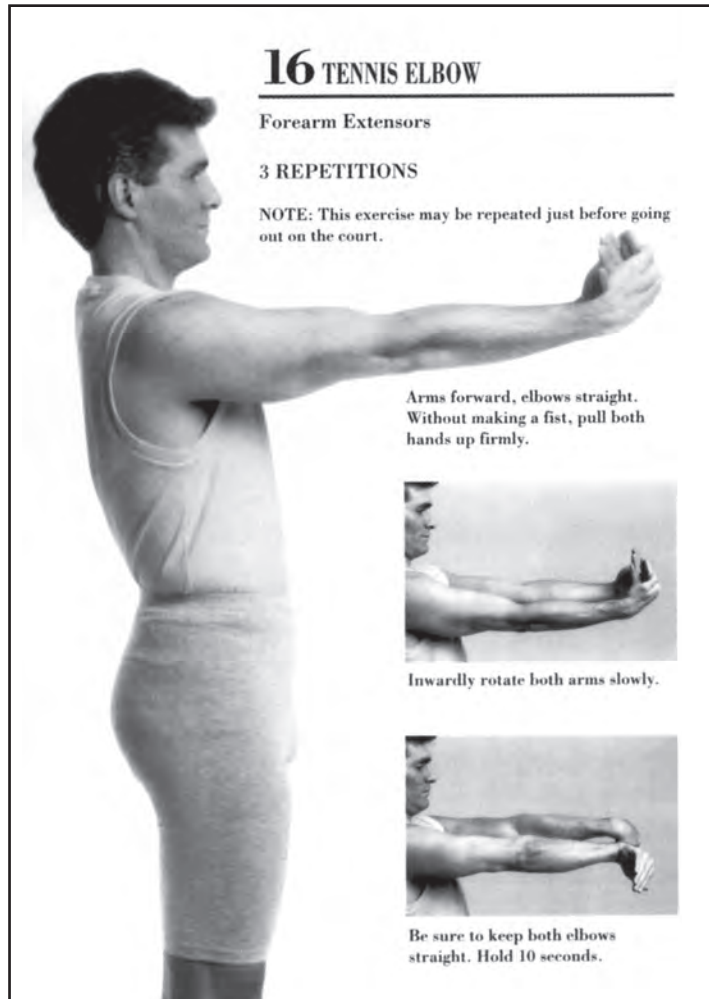

The method, called “active” stretching, incorporates the principle of reciprocal innervation of muscles, set forth by Sir Charles Sherrington at the turn of the 20<sup>th</sup> century. He proved in the laboratory what we all know naturally, that when our muscles contract, the opposing ones are inhibited and relax. Stretching procedures that take this into account eliminate force and are the only safe way to stretch.

Although *The Flexibility Manual* is a total body method, involving a series of interrelated exercises, the page reproduced here will show how straightforward and beneficial this method can be. The jarring forces of an improper backhand tennis stroke are perhaps less damaging than a woodturning catch and much less problematic than the repetitive stresses absorbed when hollowing end grain.

But regular exercises like this can really make a difference.

The important thing to recognize when stretching muscles to alleviate stress, soreness, and tightness is that force is counterproductive. Active stretching utilizes normal neuromuscular activity, slowly contracting one set of muscles in order to relax, stretch and restore flexibility to the opposing set. There is no bounding, no pain for gain, no elaborate body positions, no danger of overdoing it.

The exercise shown here is only a sample of what you can do for every muscle in your body. If you actively stretch gently and consistently every day and not merely to “get by,” you will benefit.

Your body no doubt has acquired its current state, if not of aches and pains but of reduced flexibility and range of motion, over a long period of neglect. Be patient and enjoy the gradual improvement. When re-establishing physical mobility in your life, remember that something overlooked is equal to new wealth when its usefulness is discovered.

---

*Howard Peters, a woodturner and physical therapist, operates Sports Kinetics in Berwyn, Penn. His book is available through Amazon.*

# First Aid for Woodturners

Robert W. Waddell, Thomas S. Meade, Jr., Charles A. Rula

---

**T**he initial treatment of an injury can often make a substantial improvement in the final outcome. Therefore, it's a good idea to review first aid procedures even if they're not new to you. In the process we will identify injuries requiring professional care; the photo on the facing page details a shop First Aid Kit.

Injuries happen quickly without warning and when least expected. Every shop should have a First Aid Kit and should also be equipped with a telephone, if possible, to summon help. If having a telephone is not feasible, install a loud outside horn that will attract attention.

Do not panic. Many treatment errors occur when this happens. Reconstruct the injury: How did it happen? Could there be wood splinters, fragments of glass, or metal, in the wound? Can you account for all broken tool parts? It may be well to take what you can find to the doctor if you are seeking professional care because this additional information helps in the evaluation of the injury and in searching for missing pieces.

If in your judgment medical attention is needed, do not delay. The outcome, especially in open wounds, will be improved with early care.

**Contusions (Bruises)**—Contusions usually occur from being struck with a blunt object. Swelling and bruising may begin immediately and are usually in proportion to the extent of the injury. Fractures may also be present. Treatment consists of rest, ice, compression and elevation or R.I.C.E. All bandages are useful for compression but should not be applied so tightly as to cause a tourniquet effect.

Ice can be helpful for up to 48 hours. Do not apply heat until after 48 hours because heat dilates the vessels and may cause increased bleeding. We continue to hear many patients say, "I did not know whether to apply ice or heat.

**Sprains**—In this injury, joint ligaments are stretched or torn completely. If the ligament is completely torn, instability of the joint results, usually requiring medical attention. Initially R.I.C.E. is indicated and splinting of the injured part. In woodturning the injury typically involves fingers or thumb. Popsicle sticks make great splints.

**Abrasions and Scratches**—Superficial abrasions are treated the same as scratches: They should be washed with germicidal soaps such as betadine and then covered with a light coating of antibiotic ointment and dressed with sterile dressing.

Deep abrasions may be full skin thickness and expose the fatty tissue beneath the skin. Medical attention is suggested for these. The initial treatment, however, is still careful cleansing with water and germicidal soap, antibiotic ointment, and sterile dressing. Often times this injury occurs when a fingertip touches a grinding wheel or disc/belt sander. Grit, dirt, and sawdust may be embedded deeply and can cause permanent "tattooing" of the skin. There is significant danger of infection with this type of injury because the protective barrier (skin) is lost and foreign material often carries infective bacteria.

**Splinters**—When you get a splinter in your hand STOP WORK immediately and remove it. If the splinter breaks off at skin level, removal is more difficult.

Wash your hands gently with antibacterial soap, taking care not to break off the splinter. Sterilize a needle and tweezers by boiling for 10 minutes or by heating tips with a flame. Wipe off the black carbon with an alcohol sponge and proceed. Use bright light and magnification. Many hardware stores and woodworking supply catalogs sell magnifying tweezers. Carefully loosen skin around the splinter with the needle, grasp the splinter with tweezers, and remove. If the splinter breaks off and is deeply embedded, professional help may be needed. After removal, re-clean with germicidal soap, dry the skin, apply antibiotic ointment and dress with a band-aid. Flexible band-aids stay on better.

Splinters are foreign bodies and if left alone may cause foreign-body reactions. White blood cells attack the wood in an attempt to destroy it. This results in tissue reaction (swelling, redness, pain) and the formation of pus. During this process the splinter will sometimes be pushed out and healing occurs. Infection can also be associated with this process. Some woods cause more reaction than others. Salt-treated wood is extremely irritative to soft tissue. Soft pine, for instance, can usually be fragmented by the white blood cells if the splinter is not too large, whereas a rosewood splinter may continue to cause pus formation indefinitely, or it could be walled off by fibrous tissue. Bottom line—get it out!

**Eye Injuries**—Eye injuries are common in the woodturner's shop and they're potentially very serious. The best remedy is prevention: wear shatterproof safety eyeglasses AND a face shield. If there is debris or chemicals in





# How to Be Prepared

*Dennis Belcher*

---

**Y**ou've read about safety and you've adopted safe practices in your workshop. You're collecting the dust, wearing your faceshield, keeping your head out of the danger zone, and avoiding cowboy stunts with large, irregular, and cracked chunks of wood. But by the very nature of what we do, accidents will happen. Here's a quiz that's designed to prepare you in advance, first by making you aware of some less-obvious things you can do to reduce your risks, and second, by increasing your awareness of what needs to happen after an accident occurs.

The challenge to you is to make a copy of the quiz, take it to your workshop, and complete each question. Take corrective action on those items you realize need to be improved. Bad habits can be changed, but only if we stop to consider the things we do that may be unsafe, and strengthen the safety practices we've learned.

The nearest phone to use in an emergency is \_\_\_\_\_.

Nearest hospital approved by my insurance carrier is \_\_\_\_\_.

Nearest prompt-care facility approved by my insurance carrier is \_\_\_\_\_.

Ambulance service closest to my home is \_\_\_\_\_. They are \_\_\_\_\_ minutes away.

I summon an ambulance by calling \_\_\_\_\_.

If I need help in the shop from my spouse or neighbor, I call \_\_\_\_\_.

My shop fire extinguisher is located \_\_\_\_\_.

The charge of my fire extinguisher was last checked on \_\_\_\_\_.

I regard my dust collection system as \_\_\_\_\_ inadequate \_\_\_\_\_ adequate \_\_\_\_\_ good \_\_\_\_\_ superb.

I consistently wear hearing protection in my shop \_\_\_\_\_ yes \_\_\_\_\_ no.

The electrical service/supply in my shop is \_\_\_\_\_ inadequate \_\_\_\_\_ adequate.

My plan if I develop an allergic reaction to a wood species is \_\_\_\_\_.

I have a faceshield \_\_\_\_\_ yes \_\_\_\_\_ no.

I wear a faceshield or safety glasses/goggles when I turn \_\_\_\_\_ never \_\_\_\_\_ sometimes \_\_\_\_\_ always.

I wear a dust mask or dust helmet when I turn \_\_\_\_\_ yes \_\_\_\_\_ no.

I consistently use properly sized tools for each project. Large tools for larger pieces, small tools for small projects \_\_\_\_\_ never \_\_\_\_\_ sometimes \_\_\_\_\_ always.

I have reviewed the near-accidents I have experienced on each machine that I own \_\_\_\_\_ yes \_\_\_\_\_ no.

I know and stay out of the "line of fire" for my lathe \_\_\_\_\_ yes \_\_\_\_\_ no.

I sit outside the line of fire when watching a demonstration \_\_\_\_\_ yes \_\_\_\_\_ no.

I have a safety stop for my lathe that is out of the line of fire \_\_\_\_\_ yes \_\_\_\_\_ no.

I use the tailstock when roughing out \_\_\_\_\_ never \_\_\_\_\_ sometimes \_\_\_\_\_ always.

I use the tailstock when turning out-of- round pieces \_\_\_\_\_ never \_\_\_\_\_ sometimes \_\_\_\_\_ always

The tool in my shop that I most need to improve/change/review my work habits from a safety standpoint is \_\_\_\_\_.

I use a safety shield to protect spectators when doing a demonstration \_\_\_\_\_ yes \_\_\_\_\_ no.

I clean and organize my shop regularly \_\_\_\_\_ yes \_\_\_\_\_ no.

The woodturning tool that I am most afraid of is \_\_\_\_\_.

I need to change my use of \_\_\_\_\_ to improve safe work habits.

My body clock makes \_\_\_\_\_ the most dangerous time of the day to work with power tools.

The one thing that I should do to improve the safety of my shop is \_\_\_\_\_.

# Safe woodturning is fun woodturning

Here are selected readings on safety for woodturners—**expert, shop-tested best practices** from the pages of *American Woodturner*, journal of the American Association of Woodturners.

## With this book, you'll learn about:

- faceshields and other essential personal protective gear
- collecting dangerous wood and sanding dust before you inhale it
- safety at the grinder while sharpening turning tools
- best practices for both spindle and faceplate turning
- bandsaw and chainsaw setup and safe use from the woodturner's perspective
- fitness and first aid in the workshop

Safe woodturning is fun woodturning. A little time spent with this book will help you build strong skills at the lathe while helping you learn best woodturning practices.

Since 1986, *American Woodturner* has been a genuine treasure-trove of practical and reliable information written by woodturners for their fellow woodturners. *Safety for Woodturners* is the first book in an on-going series being extracted from this authoritative source. *Safety for Woodturners* is available as a 64-page printed book or as a digital download readable on all your electronic devices.



American Association of Woodturners  
222 Landmark Center  
75 5th St. W  
St. Paul, MN 55102-7704  
877-595-9094  
[www.woodturner.org](http://www.woodturner.org)

